



Beck GmbH
Druckkontrolltechnik
Ferdinand-Steinbeis-Straße 4
71144 Steinenbronn

Operating Instructions





1	General instructions	3
1.1	Safety instructions	3
1.1.1	General safety instructions	3
1.1.2	Safety instructions for potentially explosive areas	4
1.1.3	Notes on environmental protection	4
2	Correct purpose of use	5
2.1	Application area	5
2.2	CE conformity	5
3	Storage and transportation	6
3.1	Packaging	6
3.2	Storage and transportation conditions	6
4	Installation	6
4.1	Installation	7
4.2	Connection	7
5	Start-up	9
5.1	Parameterisation	9
6	Maintenance / service	9
6.1	Time intervals	9
6.2	Troubleshooting	10
7	Repairs	10
8	Dismantling	10
8.1	Disposal	10
9	Appendix	11
9.1	Technical data and dimensioned drawing	11
9.1.1	Pressure switch 901	12
9.1.2	Pressure switch 901 Prescal®	13
9.2	Dimensioned drawings and accessories	14
9.2.1	Pressure switch 901	14
9.2.2	Pressure switch 901 Prescal®	15
9.3	Declaration of Conformity	16
9.4	EC design test certification	17
9.5	Proof of compliance with explosion protection regulations	18

Telephone +49 7157 52 87-0
Telefax +49 7157 52 87-83
E-Mail sales@beck-sensors.com
Internet https://www.beck-sensors.com
VAT-no. DE162391354

Bank Accounts
Kreissparkasse Esslingen-Nürtingen (BLZ 611 500 20) 57 011 970
S.W.I.F.T. ESSLDE66 IBAN: DE33 6115 0020 0057 0119 70
Commerzbank Stuttgart (BLZ 600 400 71) 876 179 300
S.W.I.F.T. COBADEFF600 IBAN: DE70 6004 0071 0876 1793 00
Landesbank Baden-Württemberg (BLZ 600 501 01) 2 214 306
S.W.I.F.T. SOLADEST IBAN: DE36 6005 0101 0002 2143 06
UniCredit Bank - HypoVereinsbank Stuttgart (BLZ 600 202 90) 388 773 332
S.W.I.F.T. HYVEDEMM473 IBAN: DE66 6002 0290 0388 7733 32

Location: Steinenbronn
Amtsgericht Böblingen HRB 6050
Managing Directors: Rainer Beck,
Hans-Peter Funk



1 General instructions

These operating instructions contain all of the information that is required for an efficient start-up and safe operation of **Model 901....EX** pressure switches.

- Please read these operating instructions before carrying out installations, start-ups, maintenance and repairs.
- Please ensure that these operating instructions are available at all times.
- Please follow the applicable instructions and safety regulations.
- All of the work that is described in these operating instructions must be carried out by qualified and authorised experts.
- In order to avoid problems, the prescribed maintenance must be carried out at regular intervals by appropriately trained personnel.

Symbols used

The meanings of the symbols that are used are as follows:

- Useful, important additional information.
- Dangers and safety instructions. *Important – please read!*
Failure to comply with these instructions can have a detrimental effect on persons and the operation of the equipment.
- Important instructions for use in potentially explosive areas.
Danger – please read!



1.1 Safety instructions

1.1.1 General safety instructions

- Please follow the applicable
 - Instructions and system-specific regulations (e.g. installation standards etc.)
 - Safety regulations and accident prevention regulations
- All work must be carried out by authorised and qualified personnel. These qualifications and authorisations include:
 - Training, experience and knowledge of the regulations, standards
 - Only personnel with appropriate product knowledge must carry out start-ups and maintenance
 - All repairs must be carried out by personnel who have been authorised to do so by the manufacturer
- Only original parts must be used
- Ignoring these operating instructions and making modifications to the equipment are not permitted and can lead to hazardous situations



1.1.2 Safety instructions for potentially explosive areas



- The 901..EX pressure switch is suitable for use in areas where there is a *risk of gas or dust explosion*
- Please follow the applicable
 - Instructions and system-specific regulations
- The labelling of the product must point out that important explosion protection characteristics must be adhered to during use.
 - G = Gas; D = Dust
 - Device category 1, 2, 3 or Equipment Protection Level EPL in the 3 zonal areas
 - Gas parameters: temperature class (T1...T6), explosion group (A, B, C)
 - Dust parameters: Explosion group (IIIA, B: non-conductive; IIIC: conductive);
 - Surface temperature, glow and ignition temperature
- When work is being performed such as installation, making electrical connections, making repairs or opening the housing, it must be ensured that
 - *no potentially explosive atmosphere is present*
 - *no electrical voltage is present*
 - *unintentional activation is ruled out*
- Dust deposits must be avoided (installation location, protection, cleaning etc.) in order to prevent dangerous surface temperature increases
- For the installation procedure it is necessary to take care that no electrostatic charging will be done (no high volume flow, cleaning only with damp cloth,...)
- It must be ensured that all technical and organisational protective measures are complied with and that the operation and effectiveness thereof is checked
- No modifications must be made to the equipment, since they may lead to a risk of explosion (ignition)
- The specifications of the EC design certificate are binding and must be complied with
- If the number of the EC design certificate is followed by an "X", special conditions or deviations from the standard conditions exist
- Installation, start-ups and repeated testing may only be carried out by appropriately qualified personnel
- The operator must issue a release for work before any activity (installation etc.) is carried out in potentially explosive areas.

1.1.3 Notes on environmental protection

Please help to protect the environment. Please pay attention to the environmental notes in these operating instructions:

- Chapter 3.1 "Storage": Handling of packaging materials
- Chapter 8.1 "Disposal": with regard to the product and its components

2 Correct purpose of use

2.1 Application area

➤ Purpose of use

- The adjustable pressure switches have the following main purpose
 - Factory-set pressure switch monitoring overpressure, vacuum or differential pressure of liquid and gaseous – also aggressive – media
 - Pressure setting and switching differential are factory-set by the Manufacturer
 - The pressure switch 901 Prescal© uses a scaled adjustment knob to enable the adjustment of trip and reset pressure without the use of a screwdriver.

The media that are being monitored occur in the following different phases

- *Gaseous* (main application)
 - ✓ Potentially explosive gasses and dust (natural gas, bio-gas, solvents etc.)
- *Liquid*
 - ✓ Flammable liquids (petrol, solvent etc.)

➤ Use in zones in potentially explosive areas

Pressure switches are used to monitor the pressure difference in areas of closed systems where there is a risk of gas explosion.



- The device may be used in areas where there is a risk of gas or dust explosion
- Two separate zonal areas can be connected via pressure connections P1 and P2 (areas 1 and 2)
- Zone 1,2 or zone 21,22 may apply to the pressure connections (areas 1 and 2)
- The surroundings (area 3) can be zone 1,2 or zone 21,22

Area-1	Surrounding Area-2	Equipment category Equipment Protection Level
Zone 0	Zone 1,2	1/2 G Ga/Gb
Zone 21,22	Zone 21,22	2D Db
Zone 1,2	Zone 1,2	2G Gb
Zone 21,22	Zone 21,22	2D Db

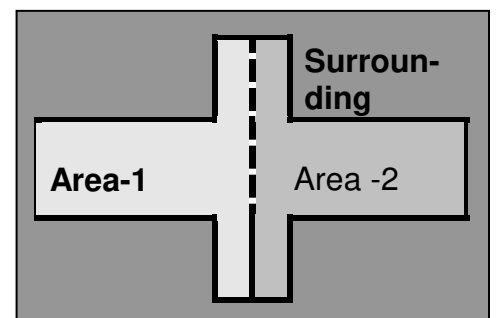

2.2 CE conformity

The product complies with the following European directives:

- Explosion protection directive
- RoHS directive

Other information and verification can be found in the

- Conformity declaration (see Chapter 9.3)



3 Storage and transportation

3.1 Packaging

The equipment is protected by packaging. The packaging is environmentally compatible and recyclable. The following main materials are used:

- Cardboard
- PE foam or PE film



Please use appropriate recycling companies to dispose of the packaging

3.2 Storage and transportation conditions

The following points must be observed in order to prevent damage:

- Avoid severe mechanical stress caused by throwing, stacking and dropping.
- Keep out of wet and rainy environments
- Do not subject to direct sunlight for long periods
- The storage temperature must not be lower than -40 °C or higher than +85 °C



4 Installation

The following checks must be performed prior to installing the equipment:

- The equipment must not show signs of damage or obvious modifications
- The IP protection class of the equipment must correspond with the usage and environmental conditions
- An operator zone definition must be available
- Check whether the equipment category corresponds with the specified zones
- With intrinsically safe systems ("i") the "associated operating materials" (barrier) must always be installed outside the potentially explosive area.
- The labelling of the product must point out that important explosion protection characteristics must be complied with during use.
 - G = Gas, D= Dust
 - Equipment Protection Level EPL/zone area
 - Parameters:
 - ✓ Temperature class (T1...T6)
 - ✓ Explosion group (A, B, C)



Equipment category	Equipment Protection Level EPL	Zone		
		0 20	1 21	2 22
1 G,D	Ga, Da	yes	yes	yes
2 G, D	Gb, Db	no	yes	yes
3 G,D	Gc ;Dc	no	no	yes

Additional information for use in areas where there is a risk of dust explosion:

- The details of the maximum surface temperature are valid only for a dust allowance of a maximum of 5 mm. At higher dust deposits must be reduced with the surface temperature.
 - Determining the maximum permissible surface temperature
 - Dust cloud with ignition temperature - $T_{CL} : T_{max1} = 2/3 T_{CL}$
 - Dust layers with glow temperature - $T_{5mm} : T_{max2} = T_{5mm} - 75^{\circ}C$

The smaller value of both must be considered for the maximum permitted surface temperature. To prevent from dangerous temperature rises dust deposits should be avoided (appropriate mounting position, use of protection covers, regular cleaning..)
- For the installation procedure it is necessary to take care that no electrostatic charging will be done (no high volume flow, cleaning only with damp cloth,...)

The following standards and directives are useful:

- EN 1127-1: Explosion protection – basic concepts and methodology



Standards for areas with risk of gas explosion (“G”, “D”):

- EN 60079-10: Classification of potentially explosive areas
- EN 60079-14: Electrical installations in potentially explosive areas
- EN 60079-17: Inspection and maintenance
- EN 60079-25: Intrinsically safe systems

4.1 Installation

Choose the installation location from the following aspects;

- Ease of access for installation, connection and operation
- Protection from direct effects of the weather, such as rain and sun
- The IP protection class of the equipment must suit the ambient conditions
- In order to prevent dangerous temperature increases on the surface of the equipment, dust deposits must be avoided (installation location, protective cover, cleaning measures etc.)



4.2 Connection

- When work is being performed such as installation, making electrical connection, making repairs or opening the housing, it must be ensured that
 - *No electrical voltage* is present
 - *Unintentional activation* is not possible
- Proceed as follows in potentially explosive areas:
 - Check whether the equipment category corresponds with the specified zones
 - *No potentially explosive atmosphere* is present
 - A release for work must have been issued by the operator
 - Adherence to the applicable regulations and documentation for the equipment
- Special notes for intrinsically safe (“i”) systems:
 - Each intrinsically safe operating material must have an associated operating material inserted before it, outside of the potentially explosive zone.
 - *Separate cable routing* for intrinsically safe and non-intrinsically safe power circuits.
 - For operating voltages of *less than 42V AC or 60V AC*: Intrinsically safe and non-intrinsically safe power circuits can be *routed together* in this case. This *only* applies to safety barrier *with galvanic separation*.
 - Separation of *intrinsically safe/non-intrinsically safe* connecting parts: at least 50mm (tight string length)
 - Distance between *different intrinsically safe power circuits*: at least 6mm
 - Distances between non-insulated *conductive parts* leading to connecting parts: air gap of at least 3mm (housing-terminals-conductor tracks, earth etc.)
- **Power supply**
 - Each intrinsically safe operating material must have an associated operating material inserted before it, outside of the potentially explosive zone:
 - ✓ Pay attention to maximum characteristics (U, I, P, L, C)
- **Select connecting cables**

The following points must be observed when selecting the cable:

 - Select cable material that complies with the local resistance requirements (mechanical, chemical)
 - Cable cross-section in accordance with electrical power and data sheet



The following points must be observed when selecting cables for intrinsically safe power circuits:

- *Diameter* of individual conductors: *greater than 0.1 mm*
- *Insulation strength* of the individual wires: *greater than 0.2 mm*
- *Test voltage* for intrinsically safe *cables*:
 - between wires, shield and earth: *500V AC*
- *Shield*: The shield area must be *60%* of the surface coverage or twisting
- *Labelling* of intrinsically safe power circuits: *colour preferably light blue*
- L and C cable characteristics must be available ($C_i=110\text{nF/km}$; $L_i=1\text{ mH/km}$)

➤ **Cable routing**

- If there is a risk of mechanical damage, the cable must be provided with additional protection (protective tube etc.)
- The cable diameter must be complied with in order to provide a tight connection in the cable lead-in.
- The screwed cable connection and the screws of the housing cover must be tightened in order to comply with the IP protection class. Over-tightening damages the housing.

➤ **Connecting the cable**

- Please ensure that the cables that are being connected are not live. otherwise there is a risk of igniting a potentially explosive atmosphere



➤ **Attach the shield**

- Attach shield at one end (in non-potentially explosive area)
- Attach braiding of shield to earth potential over a wide area.
- No potential equalisation current must be flowing between potentially explosive areas and non-potentially explosive areas. Separation using a capacitor is permitted in this case for EMC purposes (total max. 10 nF).



➤ **Earthing**

- The external earthing terminal on the housing must be connected to the potential equalisation of the potentially explosive area with low resistance (removal of electrostatic charge between 0.2-1 MOhms is considered to be earthing)
- No potential equalisation current must be flowing between potentially explosive areas and non-potentially explosive areas
- Minimum cross-section: $2 \times 1.5\text{ mm}^2$ or $1 \times 4\text{ mm}^2$
- Intrinsically safe power circuits: Housings made from *metal do not need to be earthed*. (If this is necessary anyway – functional earthing, earthing in one location only...)



➤ **Documentation**

- Operating instructions, conformity declaration, EC design test certificate
- System and zonal plan
- Proof of adherence to explosion protection regulations (see Appendix 9.5)
 - ✓ Equipment selection: category, Equipment Protection Level EPL, temperature class, explosion group, ...
 - ✓ Proof of adherence to intrinsic safety requirements



5 Start-up

Before voltage is applied to the equipment the following checks must be performed:

- Check that screws are firmly seated in
 - Connecting terminals, protective earth conductor terminals and potential equalisation terminals
 - Housing cover
- Check
 - The torque of the cable lead-in
 - The tightness of the seal provided by the cable lead-in
- Check whether the equipment is ready for operation
 - The parameterisation for this application must have been performed
 - All interfaces such as inputs and outputs for control purposes must be connected and ready for operation



5.1 Parameterisation

Equipment parameterisation

- Define all application-specific parameters.
- Once the power supply is applied, the equipment is ready for operation immediately.

6 Maintenance / service

The equipment can only be guaranteed to operate safely and reliably in the long term if regular inspections and servicing are carried out. These include the following:



For cleaning the devices it is necessary to take care that no electrostatic charging will be done (no high volume flow, cleaning only with damp cloth,...)

An **inspection** includes

- Visual inspection
 - Mechanical damage
 - Non-permitted dust deposits
 - Other irregularities or error messages from the equipment
- Checking of components (wearing parts) whose functionality or purpose changes and affects the operation of the equipment
- Documentation of what was done by whom, and when

Maintenance includes

- Functionality checking
 - Operating statuses such as alarms etc.
- Checking calibration values (= calibration)
 - Triggering of alarms by known process parameters (test pressure etc.)
- Correction of calibration values (= calibration) must be carried out in the factory
- Documentation of what was done by whom, and when

6.1 Time intervals

Inspection:

The condition of the equipment must be checked at regular intervals. The time interval is extremely dependent on the local situation and the degree of use, and must therefore be adapted to requirements. Extremely short time intervals can be specified such as once per day, every new shift etc.

- Defined by the operator in accordance with local requirements



Maintenance

- The interval from the applicable usage regulations must be taken into consideration
- As a manufacturer we recommend a maximum interval of 1 year

6.2 Troubleshooting

A list of possible faults (fault indications) can be found in the table below. The table contains an explanation of how to detect faults. A list of possible causes and remedial measures also follows.



Fault indication	Possible cause	Measures
Contact won't switch	Defective diaphragm	Replace pressure switch
	Spring defective	
	Pressure connection blocked	
	Pressure outside working range	

7 Repairs

The following points must be noted before carrying out any work whatsoever on the equipment:

- When work is being performed such as installation, making electrical connections or opening the housing, it must be ensured that
 - *No electrical voltage* is present
 - *Unintentional activation* is not possible
- Repairs must only be carried out by the manufacturer
- The following must be observed in potentially explosive areas:
 - *No potentially explosive atmosphere* is present
 - A release for work must have been issued by the operator
 - The applicable regulations and all documentation for this equipment must be adhered to
 - Only original spare parts from the manufacturer must be used
 - The spare parts must comply with the required equipment category
 - Interventions that influence explosion protection must only be carried out by *experts*. A prerequisite is adequate *qualification* ("capable person") with regard to *explosion protection* and the use of the *equipment*



8 Dismantling

The following points must be noted before carrying out any work whatsoever on the equipment:

- Ensure that the equipment may be removed and that appropriate replacement measures have been taken.
- All of the instructions in chapter 7 "Repairs" must be followed
- Exposed cable (ends) must be marked, and it must be ensured that
 - *No electrical voltage* is present
 - *Unintentional activation* is not possible



8.1 Disposal

The equipment is made from recyclable materials and is designed to make the housing and the electronics easy to separate. Please ensure that all parts are disposed of in accordance with legal regulations. Please contact us if you cannot dispose of the equipment properly.



9 Appendix

9.1 Technical data and dimensioned drawing

Temperature ranges

Ambient temperature:

- from -20 °C to +85 °C

Medium temperature:

- up to +85 °C

Storage temperature:

- from -40 °C to +85 °C

Diaphragm material

Depending on media NBR, Silicone, FKM (Viton®), EPDM.

For types 901.30 and 901.8x only Silicone diaphragms, others upon request.

Electrical rating

Values indicated for resistive load

- for Gas 1/2G or 2G: 60 mA/30 VDC or 100 mA/24 VDC
- for Dust 2D: 30V; 60mA ; 0.6W

Electrical connection

Arrangement of contacts

- for 901.1.., 901.30, 901.41, 901.51 **EX**

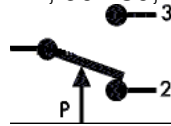

only for 901.2.. **EX**

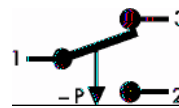

- for 901.6.., 901.8.., 901.9.. **EX**

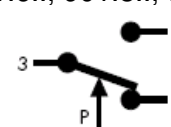

only for 901.7.. **EX**

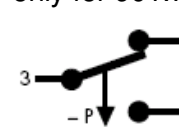

Certifications

CE conformity in according with ATEX-directive 2014/34/EU.

EC-type certification by the specified EXAM body (ID 0158) with the following ATEX labelling:

- 1/2G: Ex ia IIB T4 Ga/Gb or 2G: Ex ia IIC T4 Gb
- 2D : Ex ia IIIB T135°C Db

Characteristics:

- 1/2G or 2G : $U_i = 24/30$ V; $I_i = 100/60$ mA;
- 2D : 30V; 60mA ; 0.6W
- $L_i = 0$ mH; $C_i = 0$ nF

Life

Minimum 10^6 cycles.

Damping

Restrictors alternatively with 0.3/0.5/0.8 mm diameter.

Accessories

- Protection caps with IP 54 (intended for use in potentially explosive atmospheres)
- Various mounting brackets

Mounting position

Mounting in any position, but needs to be specified for settings below 100 mbar.



9.1.1 Pressure switch 901

- Factory-set pressure setting

Pressure connection

Type	Tube connection			Threaded connection			
	5.0 mm	6.5 mm	10.0 mm	M 10 x1	G 1/8	G 1/4	G 1/2
901.1...EX	PA	PA, PPS	PA, PPS	PA, PVDF, CuZn40, V ₂ A	PA, PVDF, CuZn40, V ₂ A	PVDF, CuZn40, V ₂ A	CuZn40
901.2...EX	PA	PA, PPS	PA, PPS	PA, PVDF, CuZn40, V ₂ A	PA, PVDF, CuZn40, V ₂ A	PVDF, CuZn40, V ₂ A	CuZn40
901.30 EX		PA					
901.41 EX		PA, PPS	PA, PPS	PA, PVDF, CuZn40, V ₂ A	PA, PVDF, CuZn40, V ₂ A	CuZn40, V ₂ A	CuZn40
901.51 EX				CuZn40	CuZn40, V ₂ A	CuZn40, V ₂ A	

PA = polyamide, PVDF = polyvinylidendifluoride, PPS = polyphenylensulfide, CuZn40 = brass, V₂A = stainless steel

Overpressure range

Type	Factory-set trip pressure		Standard switching differential		Tolerance band in % of trip pressure	Maximum positive working pressure standard/ extended	Maximum negative working pressure standard/ extended
	between	and	lower end of range	upper end of range			
901.1...EX	5 mbar	200 mbar	2.5 mbar	50 mbar	±10 %	0.5/4 bar	-/-1 bar
	200 mbar	1000 mbar	50 mbar	150 mbar	±10 %	1/4 bar	-/-1 bar
901.41 EX	500 mbar	3000 mbar	200 mbar	600 mbar	±10 %	10 bar	-1 bar
901.51 EX	1.0 bar	12 bar	0.2 bar	1.5 bar	±10 %	25 bar	-1 bar

Vacuum range

Type	Factory-set trip pressure		Standard switching differential		Tolerance band in % of trip pressure	Maximum positive working pressure standard/ extended	Maximum negative working pressure standard/ extended
	between	and	lower end of range	upper end of range			
901.2...EX	- 5 mbar	- 200 mbar	2.5 mbar	50 mbar	±10 %	0.5/4 bar	-1 bar
	- 200 mbar	- 900 mbar	50 mbar	150 mbar	±10 %	1/4 bar	-1 bar

Differential pressure range

Type	Factory-set trip pressure		Standard switching differential		Tolerance band in % of trip pressure	Maximum positive working pressure standard/ extended	Maximum negative working pressure standard/ extended
	between	and	lower end of range	upper end of range			
901.30..EX	5 mbar	50 mbar	2.5 mbar	25 mbar	±10 %	100 mbar	-100 mbar



9.1.2 Pressure switch 901 Prescal®

▪ Adjustable setting

Pressure connection

Type	Tube connection			Threaded connection			
	5.0 mm	6.5 mm	10.0 mm	M 10 x1	G 1/8	G 1/4	G 1/2
901.61-65 EX	PA	PA, PPS	PA, PPS	PA, PVDF, CuZn40, V ₂ A	PA, PVDF, CuZn40, V ₂ A	CuZn40, V ₂ A	CuZn40
901.66-68 EX				CuZn40, V ₂ A	CuZn40, V ₂ A	CuZn40, V ₂ A	CuZn40
901.71-76 EX	PA	PA, PPS	PA, PPS	PA, PVDF, CuZn40, V ₂ A	PA, PVDF, CuZn40, V ₂ A	CuZn40, V ₂ A	
901.77-78 EX				CuZn40, V ₂ A	CuZn40, V ₂ A	CuZn40, V ₂ A	CuZn40
901.8... EX		PA					
901.91-93 EX				CuZn40	CuZn40, V ₂ A	CuZn40, V ₂ A	

PA = polyamide, PVDF = polyvinylidendifluoride, PPS = polyphenylensulfide, CuZn40 = brass, V₂A = stainless steel

Overpressure range

Type	Adjustment range for trip pressure		Tolerance band in % of	Switching differential	Maximum positive working pressure standard/extended	Maximum negative working pressure standard/extended
	from	to				
901.61 EX	5	20 mbar	±10 %	3 mbar	0,5/4 bar	-/-1 bar
901.62 EX	10	50 mbar	±10 %	5 mbar	0,5/4 bar	-/-1 bar
901.63 EX	25	100 mbar	±10 %	10 mbar	0,5/4 bar	-/-1 bar
901.64 EX	50	250 mbar	±10 %	20 mbar	1/4 bar	-/-1 bar
901.65 EX	100	500 mbar	±10 %	50 mbar	1/4 bar	-/-1 bar
901.66 EX	250	1000 mbar	±10 %	150 mbar	10 bar	-1 bar
901.67 EX	500	1500 mbar	±10 %	250 mbar	10 bar	-1 bar
901.68 EX	1000	3000 mbar	±10 %	500 mbar	10 bar	-1 bar
901.91 EX	1.0	6.0 bar	±10 %	0.5 – 2.0 bar	25 bar	-1 bar
901.92 EX	4.0	9.0 bar	±10 %	0.5 – 2.0 bar	25 bar	-1 bar
901.93 EX	7.0	12.0 bar	±10 %	0.5 – 2.0 bar	25 bar	-1 bar

Vacuum range

901.71 EX	-5	-20 mbar	±10 %	3 mbar	0,5/4 bar	-/-1 bar
901.72 EX	-10	-50 mbar	±10 %	5 mbar	0,5/4 bar	-/-1 bar
901.73 EX	-25	-100 mbar	±10 %	10 mbar	0,5/4 bar	-/-1 bar
901.74 EX	-50	-125 mbar	±10 %	20 mbar	0,5/4 bar	-/-1 bar
901.75 EX	-75	-200 mbar	±10 %	25 mbar	1/4 bar	-/-1 bar
901.76 EX	-100	-300 mbar	±10 %	30 mbar	1/4 bar	-1 bar
901.77 EX	-200	-500 mbar	±10 %	75 mbar	1/4 bar	-1 bar
901.78 EX	-300	-700 mbar	±10 %	75 mbar	1/4 bar	-1 bar

Differential pressure range

901.81 EX	5	20 mbar	±10 %	3 mbar	100 mbar	-100 mbar
901.82 EX	10	50 mbar	±10 %	5 mbar	100 mbar	-100 mbar

9.2 Dimensioned drawings and accessories

9.2.1 Pressure switch 901

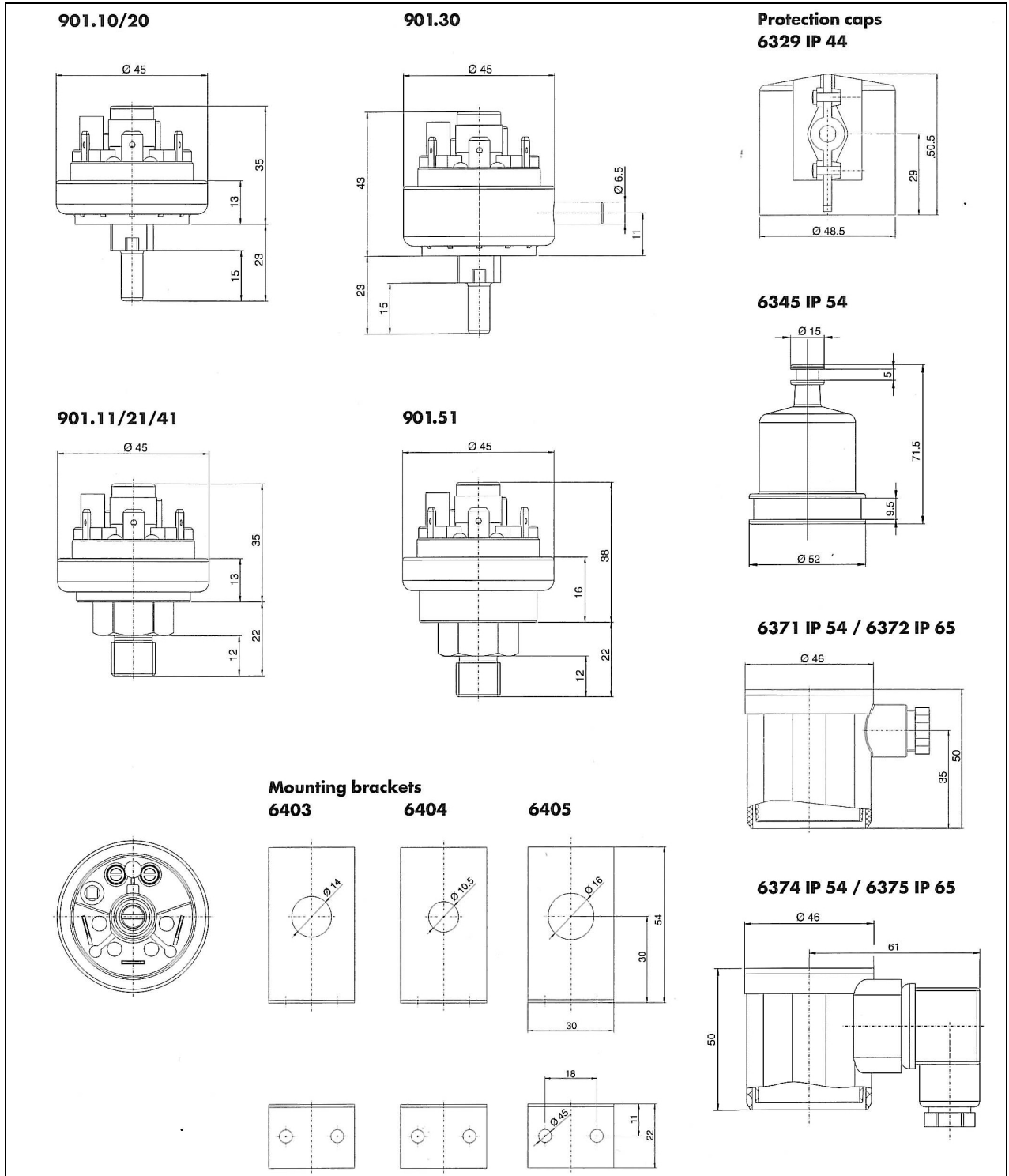

9.2.2 Pressure switch 901 Prescal®

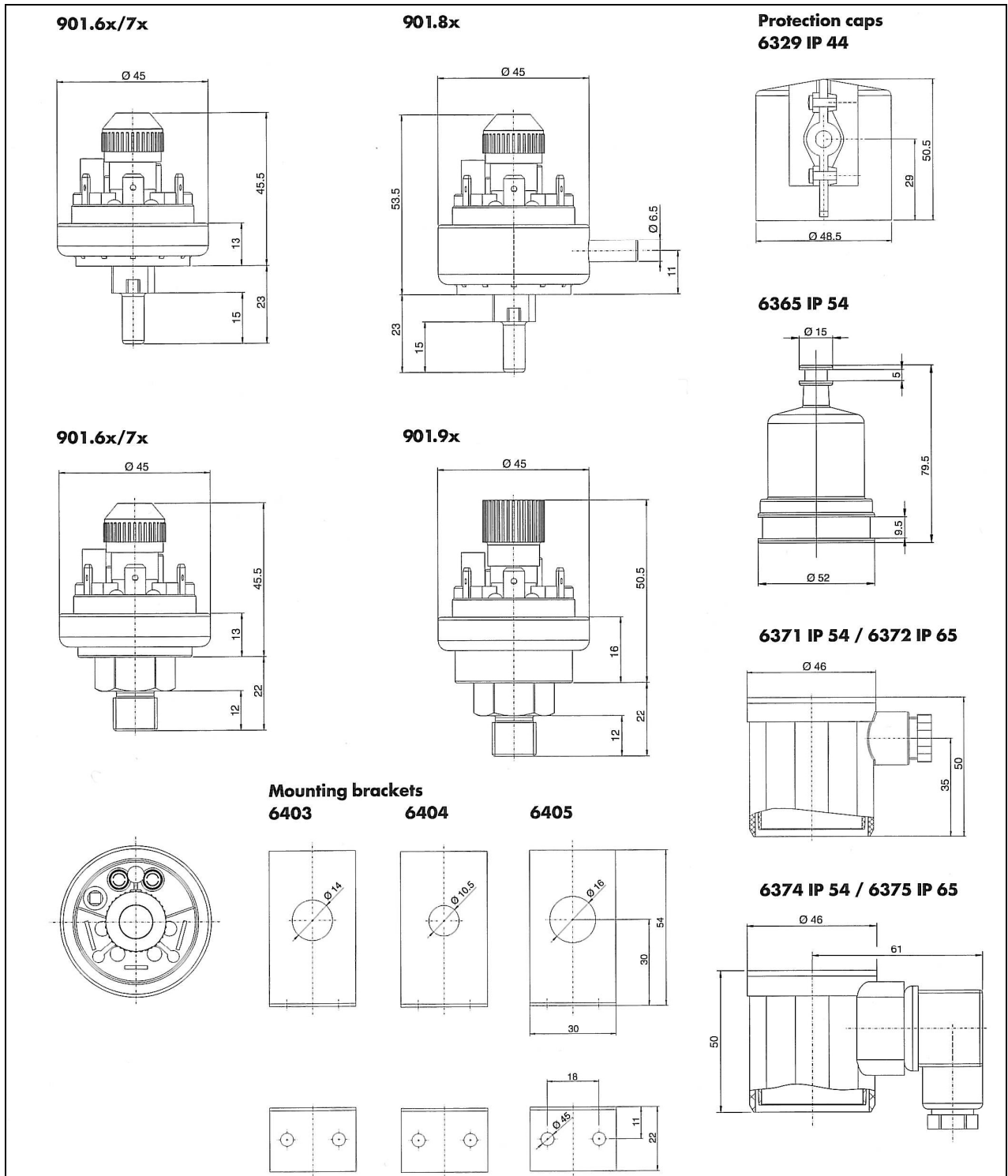



9.3 Declaration of Conformity

EU-Konformitätserklärung EU-Declaration of Conformity



Beck GmbH
Druckkontrolltechnik
Ferd.-Steinbeis-Str 4
71144 Steinenbronn
Germany

entsprechend der Explosionsschutzrichtlinie 2014/34/EU :
Geräte und Schutzsysteme zur bestimmungsgemäßen Verwendung in explosionsgefährdeten Bereichen
in accordance with ATEX- Directive 2014/34/EU:
Equipment and protective systems intended for use in potentially explosive atmospheres

Name des Herstellers: Beck GmbH Druckkontrolltechnik
Name of manufacturer:

Anschrift des Herstellers: Ferdinand-Steinbeis-Str 4, 71144 Steinenbronn, Germany
Manufacturer's address:

Produktbezeichnung: Druckwächter für Überdruck, Unterdruck, Differenzdruck
Product description: Pressure Switch for positive, negative and differential pressure

Modell: Baureihe 901...EX
Model: series 901... EX

Zur Beurteilung der Erzeugnisse hinsichtlich der Richtlinie wurden benannte Stellen miteinbezogen. Für die Verwendung in explosionsgefährdeten Bereichen wurde folgende EG-Baumusterprüfbescheinigung von einer notifizierten Stelle mit der Kennnummer-0158 ausgestellt:
The product has been assessed and tested by a notified body. For the application in explosive atmospheres the notified body with identification number -0158 certified this in the EC type examination certificate

BVS 06 ATEX E 141 X und Nachträge 1,2,3

0158: DEKRA EXAM GmbH Dinnendahlstrasse 9 D-44809 Bochum

Die grundlegenden Sicherheits- und Gesundheitsanforderungen werden erfüllt durch Übereinstimmung mit:
The essential health and safety requirements are met in conformity with:

EN 60079-0 :2012+A11:2013	Allgemeine Bestimmungen <i>General requirements</i>
EN 60079-11:2012	Eigensicherheit „i“ <i>Intrinsic safety „i“</i>

Das Produkt wird unter einem Qualitätssicherungssystem -Produktion (Anhang IV der Richtlinie) hergestellt. Dies ist durch die notifizierte Stelle der Kennnummer -0123 anerkannt worden :
The product is manufactured under the modul-product quality assurance (Annex IV of the directive). This was certified by the notified body with the identification number -0123:

EX2A 17 10 29084 006

0123: TÜV SÜD Product Service GmbH Ridlerstraße 65 D-80339 München

Kennzeichnung des Geräts  **II 1/2G Ex ia IIB T4 Ga/Gb oder/or II 2G Ex ia IIC T4 Gb**
Marking of the product **II 2D Ex ia IIIB T135°C Db**

Zusätzliche Informationen :
Additional information:
Diese Erklärung bescheinigt die Übereinstimmung mit den genannten Richtlinien, beinhaltet jedoch keine Zusicherung von Eigenschaften. Die Bedienungsanleitung und Sicherheitshinweise der mitgelieferten Produktdokumentation sind zu beachten.
This declaration confirms only the accordance with the above mentioned directive and do not cover any other characteristics. The manual and security advice of the product has to be kept in mind.

Steinenbronn, im September 2019

(Hans-Peter Funk)
Geschäftsführer-Marketing & Vertrieb
Managing director

(Ralph Weigl)
Explosionsschutzbeauftragter
Authorised ATEX-representative



9.4 EC design test certification

Note: More documentation for EC design test certification you can download from our website.



Translation

(1) **3rd Supplement to the EC-Type Examination Certificate**

(2) Equipment and protective systems intended for use in potentially explosive atmospheres - Directive 94/9/EC Supplement accordant with Annex III number 6

(3) No. of EC-Type Examination Certificate: **BVS 06 ATEX E 141 X**

(4) Equipment **Pressure sensor type 901***EX and 930***EX**

(5) Manufacturer: **Beck GmbH**

(6) Address: **Ferdinand-Steinbeis-Straße 4, 71144 Steinenbronn, Germany**

(7) The design and construction of this equipment and any acceptable variation thereto are specified in the appendix to this supplement.

(8) The certification body of DEKRA EXAM GmbH, notified body no. 0158 in accordance with Article 9 of the Directive 94/9/EC of the European Parliament and the Council of 23 March 1994, certifies that this equipment has been found to comply with the Essential Health and Safety Requirements relating to the design and construction of equipment and protective systems intended for use in potentially explosive atmospheres, given in Annex II to the Directive. The examination and test results are recorded in the test and assessment report BVS PP 06 2129 EG.

(9) The Essential Health and Safety Requirements are assured by compliance with:

EN 60079-0:2012 General requirements
EN 60079-11:2012 Intrinsic safety "i"

(10) If the sign "X" is placed after the certificate number, it indicates that the equipment is subject to special conditions for safe use specified in the appendix to this certificate.

(11) This supplement to the EC-Type Examination Certificate relates only to the design, examination and tests of the specified equipment in accordance to Directive 94/9/EC. Further requirements of the Directive apply to the manufacturing process and supply of this equipment. These are not covered by this certificate.

(12) The marking of the equipment shall include the following:

	for type 901 ***EX II 1/2G Ex ia IIB T4 Ga/Gb II 2G Ex ia IIC T4 Gb II 2D Ex ia IIIB T135°C Db	for type 930 ***EX II 2G Ex ia IIB T4 Gb II 2D Ex ia IIIB T135°C Db
-------------------------------------------------------------------------------------	---------------------------------------------------------------------------------------------------------	---------------------------------------------------------------------------

DEKRA EXAM GmbH
Bochum, dated 2014-11-03

Signed: Simanski

Certification body

Signed: Dr. Eickhoff

Special services unit

Page 1 of 2 of BVS 06 ATEX E 141 X / N3
This certificate may only be reproduced in its entirety and without any change.

DEKRA EXAM GmbH, Dinnendahlstrasse 9, 44809 Bochum, Germany,
telephone +49.234.3696-105, Fax +49.234.3696-110, zs-exam@dekra.com





9.5 Proof of compliance with explosion protection regulations

Project			
Name		Date	

Requirement		Complies with		Requirement		Complies with	
Application area	II (Gas)	III (Dust)	II (Gas)	Temperature class (Gas)		Temperature class (Gas)	
				T1	<input type="checkbox"/>	T1	400°C
				T2	<input type="checkbox"/>	T1-T2	300°C
Explosion group	A	<input type="checkbox"/>	A	T3	<input type="checkbox"/>	T1-T3	200°C
	B	<input checked="" type="checkbox"/>	A,B,C	T4	<input checked="" type="checkbox"/>	T1-T4	135°C
	C	<input type="checkbox"/>	A,B,C	T5	<input type="checkbox"/>	T1-T5	100°C
				T6	<input type="checkbox"/>	T1-T6	85°C

Requirement			Permitted Equip. Protection Level EPL (G=Gases)	Certified for	Ignition protection class
Zone	2,22	<input checked="" type="checkbox"/>	Gc,Dc	Zone 2/22	
	1,21	<input checked="" type="checkbox"/>	Gb,Db	Zone 1,2 /21,22	Ex ia IIB / Ex ia IIIB
	0,20	<input checked="" type="checkbox"/>	Ga,Da	Zone 0,1,2/ 20,21,22	Ex ia IIC

CHARACTERISTICS	Intrinsically safe operating materials			Associated operating materials
Designation	Pressure switch		Cable	Switch amplifier
Model	901 ..EX			
Application area	2G	2D	1/2G	
Ignition protection class	Ex ia ... Gb	Ex ia...Db	Ex ia.. Ga	
Explosion group	IIC	IIIB	IIB	
Temperature class	T4	T135C	T4	
Certification	BVS 06 ATEX E141X			
U _{i,a}	30V			
I _{i,a}	60mA			
P _{i,a}	600mW			
L _{i,a}	0		1mH	
C _{i,a}	0		0,1µF	

Kabelkennwerte: 1 mH/km ; 110 nF/km

	Requirement complied with
Application area	<input type="checkbox"/>
Ignition protection class	<input type="checkbox"/>
Explosion group	<input type="checkbox"/>
Temperature class	<input type="checkbox"/>
Equipment Protection Level EPL/Zone	<input type="checkbox"/>

Proof of intrinsic safety

	Associated operating materials (barriers)	Requirement	Intrinsically safe operating materials (including cable)	Compliant
U		≤	30V	<input type="checkbox"/>
I		≤	60mA	<input type="checkbox"/>
P		≤	600mA	<input type="checkbox"/>
L		≥	1mH (1km cable)	<input type="checkbox"/>
C		≥	0,1µF (1km cable)	<input type="checkbox"/>