

Progettata secondo ASME/API/EN la valvola a sfera Omal nasce per un utilizzo con attuatore, non solo perchè viene ovviamente dotata di accoppiamento standardizzato per l'attuatore stesso, ma anche dal punto di vista della conformazione delle tenute, che garantiscono un numero di cicli molto elevato. Pur nella sua essenzialità costruttiva la wafer Omal evidenzia quegli accorgimenti che la pongono al di sopra della numerosa concorrenza. La costruzione "fire safe" secondo restrittive recenti norme, i dispositivi antistatici e la complessa tenuta dello stelo, corredate dalle relative certificazioni su TA LUFT E FUGITIVE EMISSION, ATEX E FIRE SAFE, sono la premessa per l'ottenimento di prestazioni e di affidabilità a tutta prova.

Designed in compliance with ASME/API/EN, Omal ball valves are meant to operated with actuators. For this reason valves are provided with actuator connections and their sealing elements are specifically engineered for a very high number of cycles. Even if very essential from a manufacturing standpoint, Omal wafer valves are well above and beyond the competition. The "fire safe" version built in compliance with recent, very strict standards and provided with antistatic devices, a complex stem sealing system and all relevant fugitive emission, ATEX and fire safe certifications guarantees best performance and total reliability.

FIRE SAFE certificate secondo le norme API 6FA - UNI EN ISO 10497.

TA LUFT/FUGITIVE EMISSION Grazie alla particolare doppia tenuta sullo stelo, costituita da un pacco di tenute a V caricato da molle a tazza, la valvola Omal è certificata secondo le severe norme sulle emissioni VDI 2440.

ATEX Le connessioni albero-corpo e albero-sfera sono dotate di dispositivo antistatico che assicura continuità elettrica: la valvola risulta così in accordo con la direttiva 94/9 EC - ATEX

STELO Montato dall'interno, risulta quindi anti-espulsione. Una doppia rondella antifrizione in PTFE assicura rotazione dell'albero a basso attrito, e alto numero di azionamenti garantendo un'ottima funzionalità alla valvola anche attuata.

FIRE SAFE: certificate in compliance with API 6 FA – UNI EN ISO 10497 standards.

TA LUFT/FUGITIVE EMISSION Thanks to the special stem double sealing system consisting of a V-pack loaded with Omal springs washer. OMAL valves are certified in compliance with very strict emission standards TA LUFT Tal – 194058 – 001

ATEX: The body-stem and ball-stem connections are provided with antistatic devices which guarantee power continuity. The valve is in compliance with Directive 94/9 EC – ATEX

STEM: Being assembled inside, the stem is completely anti blow-out. A double anti-friction washer in PTFE allows the stem to rotate with low friction and the valve to perform flawlessly for a very high number of cycles.



ESECUZIONE STANDARD

Sfera flottante
 Tenuta soft-seat (TFM 1600)
 Norme per flange d'attacco EN 1092-1 ed. 2008; ANSI B 16.5
 Temperatura di utilizzo: da -40°C a +200°C (vedi diagramma pressione temperatura)
 Pressione di utilizzo: PN16-40; ANSI 150-300
 Fluido intercettato: aria, acqua, gas, prodotti petroliferi e petrolchimici, fluidi aggressivi.
 Antistatic device EN12662-2
 Tenuta stelo: pacco a V di serie in TFM
 Tenuta addizionale su stelo con O-ring
 Stelo anti Blow-out
 Foratura piano per attuatore a norma ISO 5211
 Angolo di chiusura >7°

ESECUZIONI SPECIALI A RICHIESTA

Per altri tipi di flangiature contattare il nostro ufficio commerciale.
 Guarnizioni di tenuta in: PTFE caricato vetro (RPTFE-GF), PTFE caricato carbografite (RPTFE-CF). Per altri tipi di materiale contattare il nostro ufficio commerciale
 Tenuta integrale avvolgente in PTFE
 Esecuzione monodirezionale con foro di compensazione della pressione nella sfera
 Leva inox
 Dadi e molle stelo inox
 Per esecuzioni speciali con materiali (corpo/sfera/stelo) diversi dallo standard contattare il nostro ufficio commerciale

CERTIFICAZIONI

Conforme alla direttiva Europea 97/23 EC PED
 Conforme alla direttiva ATEX 94/9/CE
 Fugitive Emission UNI EN ISO 15848:2006
 TA-LUFT VDI 2440:2000
 FIRE SAFE: certificate secondo API 607:2005/ISO 10497:2010 e API6FA:1999

NORME DI PROGETTAZIONE UTILIZZATE

Spessori corpo in accordo a: ASME B16.34, ASME VIII div.1, EN 12516.
 Materiali e rating in accordo ad ASME B16.34 per valvole ANSI ed EN 12516 per valvole PN

STANDARD FEATURES

No protruding floating ball
 Soft-seat seal (TFM 1600)
 Standard for connecting flanges: EN 1092-1 ed. 2008; ANSI B16.5
 Operating temperature: from -40°C to +200°C (see temperature pressure diagram)
 Operating pressure: PN16-40 - ANSI 150-300
 Intercepted fluid: air, water, gas, petroleum and petrochemical products, aggressive fluids
 Antistatic device EN12662-2
 Stem seal: TFM 1600 V-pack
 Additional seal on stem with FKM O-ring
 Anti Blow-out stem
 Actuator connection as per standard ISO 5211
 Closing angle >7°

SPECIAL FEATURES ON REQUEST

For other flange types please contact our sales department.
 Sealing in: PTFE reinforced with glass (RPTFE-GF), PTFE reinforced with carbon-graphite (RPTFE-CF). For other types of materials please contact our sales department
 PTFE cavity filler seat
 Mono-directional version with pressure-relief hole in the ball
 Stainless steel lever
 Stainless steel Stem nuts and springs
 For special versions in materials different from the standard (body, ball, stem), please contact our sales department.

CERTIFICATIONS

In compliance with European Directive 97/23 EC PED
 In compliance with ATEX 94/9/CE Directive (on request)
 Fugitive Emission UNI EN ISO 15848:2006
 TA-LUFT VDI 2440.2000
 FIRE SAFE: certified according API 607:2005/ISO 10497:2010 e API6FA:1999

ENGINEERING STANDARDS EMPLOYED

Body thickness in compliance with: ASME B16.34, ASME VIII div.1, EN 12516.
 Materials and rating in compliance with ASME B16.34 for ANSI valves and EN 12516 for PN valves



SPLIT WAFER IN ACCIAIO AL CARBONIO PN 16-40 ANSI 150-300 CARBON STEEL SPLIT WAFER PN 16-40 ANSI 150-300



ESECUZIONE STANDARD

Sfera flottante
Tenuta soft-seat (TFM 1600)
Norme per flange d'attacco EN 1092-1 ed.2008;ANSI B 16.5
Temperatura di utilizzo: da -10°C a +200°C (vedi diagramma pressione temperatura)
Pressione di utilizzo: PN16-40; ANSI 150-300
Fluido intercettato: aria, acqua, gas, prodotti petroliferi.
Antistatic device EN12662-2
Tenuta stelo: pacco a V di serie in TFM
Tenuta addizionale su stelo con O-ring
Stelo anti Blow-out
Foratura piano per attuatore a norma ISO 5211
Angolo di chiusura >7°
Trattamento superficiale brunitura

ESECUZIONI SPECIALI A RICHIESTA

Esecuzione per temperatura -40 C° in LF2
Per altri tipi di flangiature contattare il nostro ufficio commerciale.
Guarnizioni di tenuta in:PTFE caricato vetro (RPTFE-GF), PTFE caricato carbografite (RPTFE-CF). Per altri tipi di materiale contattare il nostro ufficio commerciale
Tenuta integrale avvolgente in PTFE
Esecuzione monodirezionale con foro di compensazione della pressione nella sfera
Leva inox
Dadi e molle stelo inox
Per esecuzioni speciali con materiali (corpo/sfera/stelo) diversi dallo standard contattare il nostro ufficio commerciale
Trattamento superficiale: zincatura bianca, verniciatura epossidica, (per altri trattamenti contattare il nostro ufficio commerciale).

CERTIFICAZIONI

Conforme alla direttiva Europea 97/23 EC PED
Conforme alla direttiva ATEX 94/9/CE
Fugitive Emission UNI EN ISO 15848.2006)
TA-LUFT VDI 2440.2000
FIRE SAFE: certificate secondo API 607:2005/ISO 10497:2010 e API6FA:1999

NORME DI PROGETTAZIONE UTILIZZATE

Spessori corpo in accordo a: ASME B16.34, ASME VIII div.1, EN 12516.
Materiali e rating in accordo ad ASME B16.34 per valvole ANSI ed EN 12516 per valvole PN

STANDARD FEATURES

No protruding floating ball
Soft-seat seal (TFM 1600)
Standard for connecting flanges: EN 1092-1 ed. 2008; ANSI B16.5
Operating temperature: from -10°C to +200°C (see temperature pressure diagram)
Operating pressure: PN16-40; ANSI 150-300
Intercepted fluid: air, water, gas, petroleum and petrochemical products.
Antistatic device EN12662-2
Stem seal: TFM 1600 V-pack
Additional seal on stem with FKM O-ring
Anti Blow-out stem
Actuator connection as per standard ISO 5211
Closing angle >7°
Superficial treatment: blueing

SPECIAL FEATURES ON REQUEST

LF2 carbon steel for low temperature execution (-40 C°)
For other flange types please contact our sales department.
Sealing in: PTFE reinforced with glass (RPTFE-GF), PTFE reinforced with carbon-graphite (RPTFE-CF) . For other types of materials please contact our sales department
Cavity filler seat in PTFE
Mono-directional version with pressure-relief hole in the ball
Stainless steel lever
For special versions in materials different from the standard (body, ball, stem), please contact our sales department.
Stainless steel Stem nuts and springs
Superficial treatment: white zinc coating ,epoxy coating
For other coating please contact our sales department

CERTIFICATIONS

In compliance with European Directive 97/23 EC PED
In compliance with ATEX 94/9/CE Directive (on request)
Fugitive Emission UNI EN ISO 15848.2006
TA-LUFT VDI 2440.2000
FIRE SAFE: certified according API 607:2005/ISO 10497:2010 e API6FA:1999

ENGINEERING STANDARDS EMPLOYED

Body thickness in compliance with: ASME B16.34, ASME VIII div.1, EN 12516.
Materials and rating in compliance with ASME B16.34 for ANSI valves and EN 12516 for PN valves

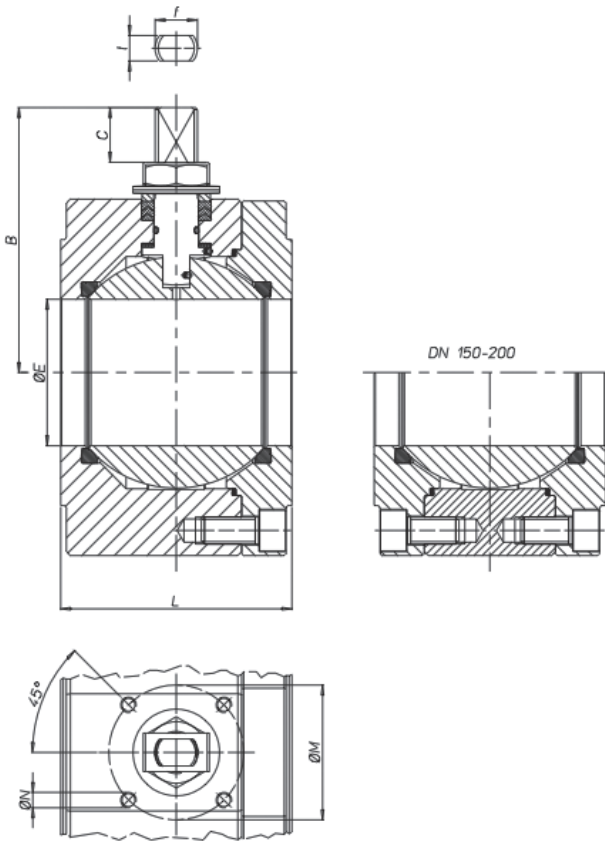

MISURA SIZE	ØE	L	B	C	ATT.ISO	ØM	ØN	f/t
DN15	13	53	52	10	F03	36	M5	10/6
DN20	19	53	55	10	F03	36	M5	10/6
DN25	25	58	68	15	F04	42	M5	12/8
DN32	32	65	73	15	F04	42	M5	12/8
DN40	38	79	93	21	F05	50	M6	16/10
DN50	51	90	102	21	F05	50	M6	16/10
DN65	64	107	130,5	28	F07	70	M8	22/14
DN80	76	120	137,5	28	F07	70	M8	22/14
DN100	102	167	172	35	F10	102	M10	30/18
DN125	118	180	182	35	F10	102	M10	30/18
DN150	152	240	227,5	40,5	F14	140	M16	45/30
DN200	203	314	274	44,8	F14	140	M16	52/35

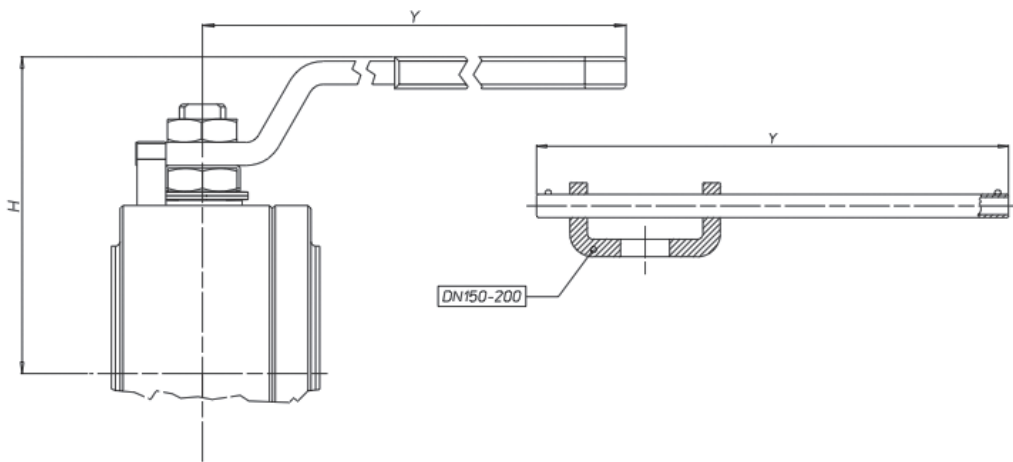

	DN15	DN20	DN25	DN32	DN40	DN50	DN65	DN80	DN100	DN125	DN150	DN200
H	70	73	86	91	108	117	142	149	198	208	274	321
Y	140	140	150	150	275	275	350	350	450	450	800	800

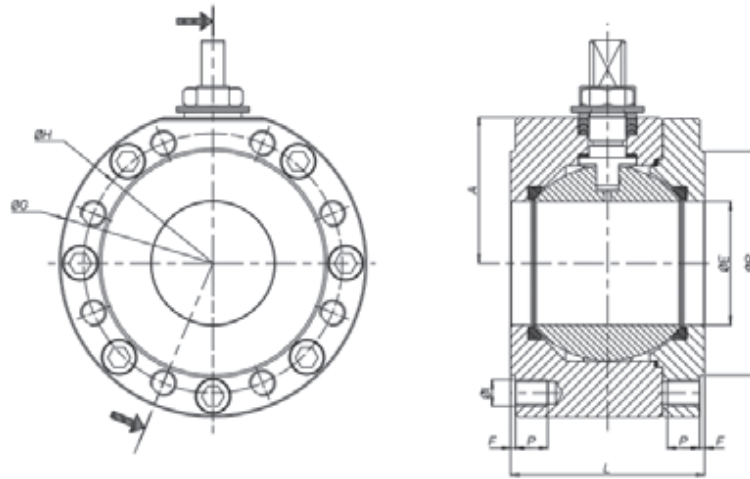

CODICE VALVOLA ASSE NUDO / BARE SHAFT VALVE CODE (V_)
CODICE VALVOLA A LEVA / LEVER OPERATED VALVE CODE (L_)

CORPO / body Stainless steel	CORPO / body Carbon steel	MISURA size	PN/ANSI	A	ØG	ØR	F	ØH	N°FORI	ØI	P	Kg	L
L/V485B0604	L/V585A0604	DN15	PN 16-40	32	90	45	2	65	4	M12	15	2.1	53
L/V485BC604	L/V585AC604	DN15	ANSI 150	32	90	35	1.6	60.3	4	1/2"UNC	16	2.1	53
L/V486BC604	L/V586AC604	DN15	ANSI 300	34	90	3	1.6	66.7	4	1/2"UNC	16	2.1	53
L/V485B0605	L/V585A0605	DN20	PN 16-40	35	100	58	2	75	4	M12	14	2.4	53
L/V485BC605	L/V585AC605	DN20	ANSI 150	35	100	43	1.6	69.8	4	1/2"UNC	16	2.5	53
L/V486BC605	L/V586AC605	DN20	ANSI 300	40	110	43	1.6	82.5	4	5/8"UNC	16	3.1	53
L/V485B0606	L/V585A0606	DN25	PN 16-40	42	110	68	2	85	4	M12	16	3.5	58
L/V485BC606	L/V585AC606	DN25	ANSI 150	42	110	51	1.6	79.4	4	1/2"UNC	16	3.4	58
L/V486BC606	L/V586AC606	DN25	ANSI 300	45	120	51	1.6	88.9	4	5/8"UNC	20	3.8	58
L/V485B0607	L/V585A0607	DN32	PN 16-40	47	130	78	2	100	4	M16	20	5.2	65
L/V485BC607	L/V585AC607	DN32	ANSI 150	47	130	63.5	1.6	89	4	1/2"UNC	20	5.2	65
L/V486BC607	L/V586AC607	DN32	ANSI 300	47	130	63.5	1.6	98.4	4	5/8"UNC	20	5.2	65
L/V485B0608	L/V585A0608	DN40	PN 16-40	58	140	88	3	110	4	M16	20	7.5	79
L/V485BC608	L/V585AC608	DN40	ANSI 150	58	140	73	1.6	98.4	4	1/2"UNC	20	7.5	79
L/V486BC608	L/V586AC608	DN40	ANSI 300	58	150	73	1.6	114.3	4	3/4"UNC	25	8.6	79
L/V485B0609	L/V585A06009	DN50	PN 16-40	67	150	102	3	125	4	M16	20	9.7	90
L/V485BC609	L/V585AC609	DN50	ANSI 150	67	150	92	1.6	120.6	4	5/8"UNC	20	9.7	90
L/V486BC609	L/V586AC609	DN50	ANSI 300	73	160	92	1.6	127.0	8	5/8"UNC	20	11.2	90
L/V485B0610	L/V585A0610	DN65	PN16	83	178	122	3	145	4	M16	20	16.4	107
L/V486B0610	L/V586A0610	DN65	PN25	83	178	122	3	145	8	M16	20	16.1	107
L/V485BC610	L/V585AC610	DN65	ANSI 150	83	178	104.7	1.6	139.7	4	5/8"UNC	20	16.5	107
L/V486B0610	L/V586AC610	DN65	ANSI 300	89	190	104.7	1.6	149.2	8	3/4"UNC	25	18.7	107
L/V485B0611	L/V585A0611	DN80	PN 16-40	90	190	138	3	160	8	M16	20	20.2	120
L/V485BC611	L/V585AC611	DN80	ANSI 150	90	190	127	1.6	152.4	4	5/8"UNC	20	20.7	120
L/V486BC611	L/V586AC611	DN80	ANSI 300	96	205	127	1.6	168.3	8	3/4"UNC	25	24.0	120
L/V485B0612	L/V585A0612	DN100	PN16	107	235	158	3	180	8	M16	20	40.4	167
L/V486B0612	L/V586A0612	DN100	PN 25-40	107	235	162	3	190	8	M20	25	40.5	167
L/V485BC612	L/V585AC612	DN100	ANSI 150	107	235	157.2	1.6	190.5	8	5/8"UNC	20	40.7	167
L/V486BC612	L/V586AC612	DN100	ANSI 300	115	250	157.2	1.6	200.0	8	3/4"UNC	25	48.2	167
L/V485B0613	L/V585A0613	DN125	PN16	117	250	188	3	210	8	M16	25	48.2	180
L/V486B0613	L/V586A0613	DN125	PN 25-40	125	270	188	3	220	8	M24	30	57.9	180
L/V485BC613	L/V585AC613	DN125	ANSI 150	117	250	185.7	1.6	216	8	3/4"UNC	30	48.3	180
L/V485B0614	L/V585A0614	DN150	PN16	154	332	212	3	240	8	M20	25	109.3	240
L/V485BC614	L/V585AC614	DN150	ANSI 150	154	332	216	1.6	241.3	8	3/4"UNC	25	110.3	240
L/V485B0615	L/V585A0615	DN200	PN16	188	396	268	3	295	12	M20	30	191.8	314
L/V485BC615	L/V585AC615	DN200	ANSI 150	188	396	269.8	1.6	298.4	8	3/4"UNC	30	193.7	314

Tabella dei materiali / Materials table	Corpo in acciaio inox Stainless steel body	Corpo in acciaio al carbonio Carbon steel body
	V485 / V486	V585 / V586
1 Corpo / body	ASTM A182 F316 / A478 TP.316 (X) (1,4401 / XCRNIMO17-12-2)	ASTM A 105 (*)
2 Ghiera / ring nut	ASTM A182 F316 / A478 TP.316 (X) (1,4401 / XCRNIMO17-12-2)	ASTM A 105 (*)
3 Sfera / ball	ASTM A351 CF8M (1,4408 / GX5CrNiMo19-12-2)	ASTN A351 CF8(**) (1,4308 / GX5CrNiMo19-10)
4 Stelo / stem	ASTM A182 F316 / A479 TP.316 / A564 -TP630 (1,4401 / X5CrNiMo17-12-2) / 174 PH (AISI 630)	ASTM A182 F6A / A479 TP.410 (***) (1,4006 / X12Cr13)
5 Sedi / seats	TFM 1600	TFM 1600
6 Guarnizione ghiera / ring nut gasket	GRAFOIL	GRAFOIL
7 Tenuta inferiore / bottom sealing	TFM 1600 (*)	TFM 1600 (*)
8 Pacco a "V" / chevron rings	TFM 1600 (*)	TFM 1600 (*)
9 O-Ring Stelo / stem o'ring	FKM (*)	FKM (*)
10 Anello premiguarnizione / gland nut ring	ASTM A182 F304 / A479 TP.304 (1,4301 / X5CrNi18-10)	Carbon Steel ZINCATO - galvanized (x) (1)
11 Piastra bloccadado / nut holder	AISI 304	AISI 304
12 Dado Stelo / stem nut (x)	UNI 3740-1 6S ZINCATO-galvanized (x)	UNI 3740-1 6S ZINCATO-galvanized (x)
13 Molle a tazza / spring washer (x)(x)	50CrV4 ZINCATO-galvanized (xx)	50CrV4 ZINCATO-galvanized (xx)
14 Dispositivo antistatico / antistatic device	ASTM A182 F316 / A479 TP.316	ASTM A182 F316 / A479 TP.316
19 Vite Corpo Ghiera / body ring nut screw	A2-70 UNI 3740	8.8 uni 3740 - galvanized
15 Controdado / lock nut (x)	UNI 3740-1 6S ZINCATO - galvanized (x)	UNI 3740-1 6S ZINCATO - galvanized (x)
16 Vite per fermo posizione / holder srew	A2 UNI EN ISO 3506-1	A2 UNI EN ISO 3506-1
17 Fermo di posizione / holder	Carbon Steel ZINCATO - galvanized	Carbon Steel ZINCATO - galvanized
18 Leva / lever (x)	Fe 37 ZINCATO galvanized (x)	Fe 37 ZINCATO galvanized (x)

A RICHIESTA DISPONIBILE IN: AVAILABLE ON REQUEST:

(*) A350LF2 (x) 304 s.s.
 (**) A351 CF8M (xx) 301 s.s.
 (***) 316 S.S.

(1) per DN 150-200 disponibile solo in 304 s.s.
 for DN 150-200 only 304 s.s.

(*) Altri materiali disponibili a richiesta Other materials available on request

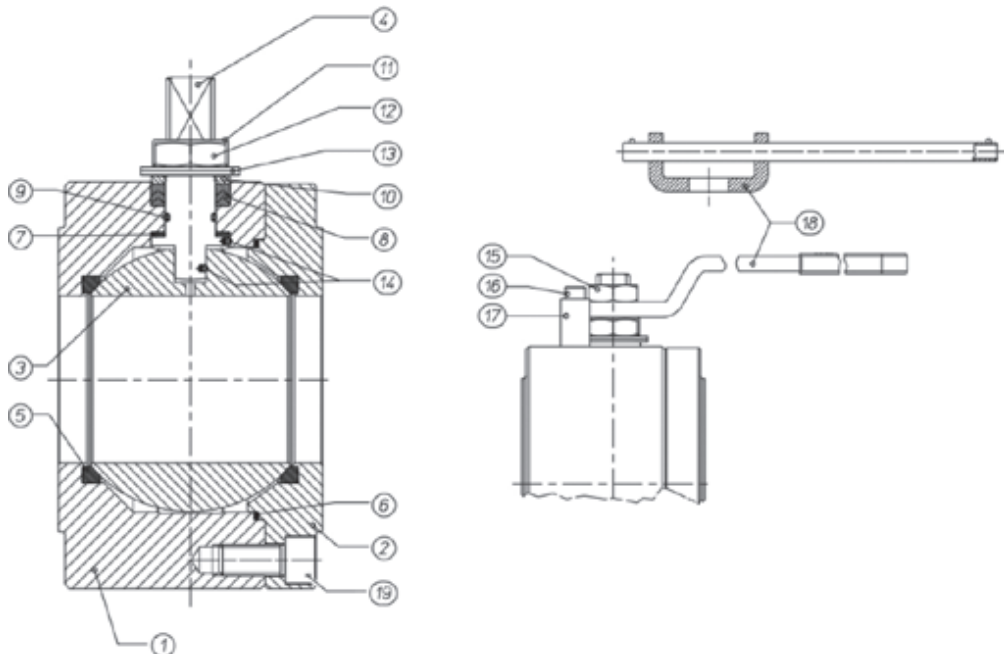

ATTUATORE PENUMATICO DOPPIO EFFETTO <i>DOUBLE ACTING PNEUMATIC ACTUATOR</i> PN 16-40									
CORPO/BODY STAINLESS STEEL	CORPO/BODY CARBON STEEL	ATTUATORE actuator	KIT di montaggio connecting kit	MISURA size	PN	N	H	Kg	L
D485BH064	D585AH064	DA015401S	KCF033761	DN15	16	115	144.4	3.2	53
D486BH064	D586AH064	DA030401S	KCF033761	DN15	25-40	130	152.4	3.4	53
D485BH065	D585AH065	DA030401S	KCF033761	DN20	16-40	130	155.4	3.8	53
D485BH066	D585AH066	DA030401S	KCF033760	DN25	16-40	130	162.4	3.5	58
D485BH067	D585AH067	DA045402S	KCF043762	DN32	16-40	144	172.7	6.6	65
D485BH068	D585AH068	DA060402S	KCF043763	DN40	16-40	152	198.4	9.2	79
D485BH069	D585AH069	DA090401S	KCF053764	DN50	16	169	214.5	11.7	90
D486BH069	D586AH069	DA120401S	KCF053764		25-40	184	233.4	12.5	
D485BH070	D585AH070	DA120401S	KCF053773	DN65	16	184	259.4	19.5	107
D486BH070	D586AH070	DA180401S	KCF073765		25-40	212	269	19.8	
D485BH071	D585AH071	DA180401S	KCF073765	DN80	16	212	276	23.5	120
D486BH071	D586AH071	DA240401S	KCF073765		25-40	242	284.4	25.5	
D485BH072	D585AH072	DA360401S	KCF103777	DN100	16	264	334	48.9	167
D486BH072	D586AH072	DA480401S	KCF103777		25-40	295	349	50.1	
D485BH073	D585AH073	DA480401S	KCF103777	DN125	16	295	359	57.8	180
D486BH073	D586AH073	DA720401S	KCF123898		25-40	329.5	383	71.9	
D485BH074	D585AH074	DA720401S	KCF123900	DN150	16	435	481	132	240
D485BH075	D585AH075	D1440401S	KCF143902	DN200	16	468	539	220	314

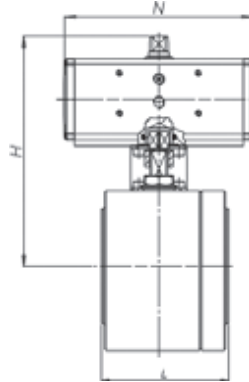

ATTUATORE PENUMATICO DOPPIO EFFETTO <i>DOUBLE ACTING PNEUMATIC ACTUATOR</i> ANSI 150-300									
CORPO/BODY STAINLESS STEEL	CORPO/BODY CARBON STEEL	ATTUATORE actuator	KIT di montaggio connecting kit	MISURA size	PN	N	H	Kg	L
D485BHC64	D585AHC64	DA015401S	KCF033761	DN15	Ansi 150	115	144.4	3.2	53
D486BHC64	D586AHC64	DA030401S	KCF033882	DN15	Ansi 300	130	154.4	3.4	53
D485BHC65	D585AHC65	DA030401S	KCF033761	DN20	Ansi 150	130	155.4	3.6	53
D486BHC65	D586AHC65	DA030401S	KCF033883		Ansi 300	130	159.4	4.5	
D485BHC66	D585AHC66	DA030401S	KCF033760	DN25	Ansi 150	130	162.4	4.8	58
D486BHC66	D586AHC66	DA030401S	KCF033884		Ansi 300	130	165.4	5.2	
D485BHC67	D585AHC67	DA045402S	KCF043762	DN32	Ansi 150	144	172.7	6.9	65
D486BHC67	D586AHC67	DA045402S	KCF043762		Ansi 300	144	172.7	6.9	
D485BHC68	D585AHC68	DA060402S	KCF043763	DN40	Ansi 150	152	198.4	9.9	79
D486BHC68	D586AHC68	DA060402S	KCF043763		Ansi 300	152	198.4	11.1	
D485BHC69	D585AHC69	DA090401S	KCF053764	DN50	Ansi 150	169	214.5	11.8	90
D486BHC69	D586AHC69	DA120401S	KCF053885		Ansi 300	184	239.4	13.0	
D485BHC70	D585AHC70	DA120401S	KCF053773	DN65	Ansi 150	184	259.4	19.5	107
D486BHC70	D586AHC70	DA180401S	KCF073886		Ansi 300	212	275	22.5	
D485BHC71	D585AHC71	DA180401S	KCF073765	DN80	Ansi 150	212	276	24.1	120
D486BHC71	D586AHC71	DA240401S	KCF073886		Ansi 300	242	294.4	27.8	
D485BHC72	D585AHC72	DA360401S	KCF103777	DN100	Ansi 150	264	334	49.0	167
D486BHC72	D586AHC72	DA480401S	KCF103904		Ansi 300	295	357	57.8	
D485BHC73	D585AHC73	DA480401S	KCF103777	DN125	Ansi 150	295	359	57.9	180
D485BHC74	D585AHC74	DA720401S	KCF123900	DN150	Ansi 150	435	481	133	240
D485BHC75	D585AHC75	D1440401S	KCF143902	DN200	Ansi 150	468	539	222	314

ATTUATORE PNEUMATICO SEMPLICE EFFETTO				SPRING RETURN PNEUMATIC ACTUATOR				PN 16-40	
CORPO/BODY STAINLESS STEEL	CORPO/BODY CARBON STEEL	ATTUATORE actuator	KIT di montaggio connecting kit	MISURA size	PN	N	H	Kg	L
S485BH064	S585AH064	SR015401S	KCF033761	DN15	16	221	152.4	3.7	53
S486BH064	S586AH064	SR030402S	KCF043767		25-40	240	162.4	4.1	
S486BH065	S585AH065	SR030402S	KCF043767	DN20	16-40	240	165.4	4.8	53
S485BH066	S585AH066	SR030402S	KCF043807	DN25	16-40	240	172.4	5.9	58
S485BH067	S585AH067	SR045401S	KCF053768	DN32	16-40	294	184.5	8.2	65
S485BH068	S585AH068	SR060401S	KCF053764	DN40	16-40	320	224.4	12.7	79
S485BH069	S585AH069	SR090401S	KCF073769	DN50	16	357	243	14.2	90
S486BH069	S586AH069	SR120401S	KCF073769		25-40	372	253.4	16.1	
S485BH070	S585AH070	SR120401S	KCF073765	DN65	16	372	279.4	22.9	107
S486BH070	S586AH070	SR180401S	KCF103770		25-40	436	291	25.3	
S485BH071	S585AH071	SR180401S	KCF103770	DN80	16	436	298	30.2	120
S486BH071	S586AH071	SR240401S	KCF103770		25-40	456	310	31.0	
S485BH072	S585AH072	SR360401S	KCF123778	DN100	16	566	365	58.2	167
S486BH072	S586AH072	SR480401S	KCF123778		25-40	602	377.2	59.6	
S485BH073	S585AH073	SR480401S	KCF123778	DN125	16	602	387.2	67.3	180
S486BH073	S586AH073	SR720401S	KCF143899		25-40	712	421	86.6	
S485BH074	S585AH074	SR720401S	KCF143901	DN150	16	834	613	172.3	240
S485BH075	S585AH075	SR1440E16D8A	KCF163903	DN200	16	975	622.5	265	314

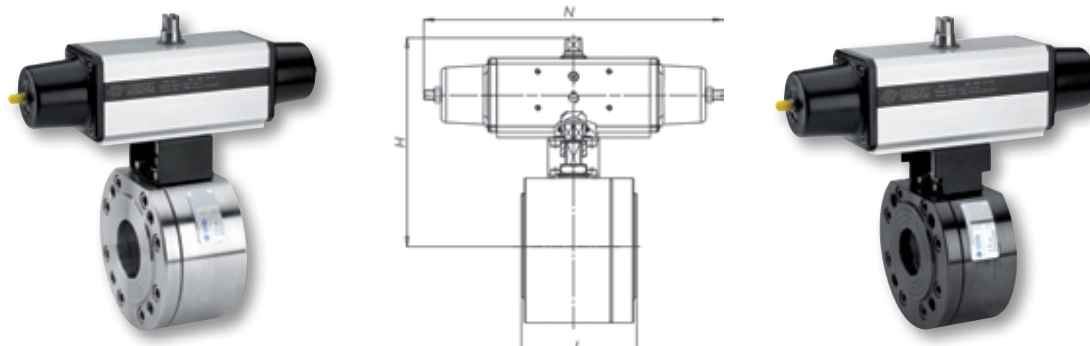

ATTUATORE PNEUMATICO SEMPLICE EFFETTO				SPRING RETURN PNEUMATIC ACTUATOR				ANSI 150-300	
CORPO/BODY STAINLESS STEEL	CORPO/BODY CARBON STEEL	ATTUATORE actuator	KIT di montaggio connecting kit	MISURA size	ANSI	N	H	Kg	L
S485BHC64	S585AHC64	SR015401S	KCF033761	DN15	Ansi 150	221	152.4	3.7	53
S486BHC64	S586AHC64	SR030402S	KCF043888		Ansi 300	240	164.4	4.1	
S485BHC65	S585AHC65	SR030402S	KCF043767	DN20	Ansi 150	240	165.4	4.9	53
S486BHC65	S586AHC65	SR030402S	KCF043889		Ansi 300	240	169.4	4.5	
S485BHC66	S585AHC66	SR030402S	KCF043807	DN25	Ansi 150	240	172.4	5.7	58
S486BHC66	S586AHC66	SR030402S	KCF043890		Ansi 300	240	175.4	6.1	
S485BHC67	S585AHC67	SR045401S	KCF053768	DN32	Ansi 150	294	184.5	8.2	65
S486BHC67	S586AHC67	SR045401S	KCF053768	DN40	Ansi 300	294	184.5	8.2	79
S485BHC68	S585AHC68	SR060401S	KCF053764		Ansi 150	320	224.4	13.3	
S486BHC68	S586AHC68	SR060401S	KCF053764	DN50	Ansi 300	320	224.4	14.4	90
S485BHC69	S585AHC69	SR090401S	KCF073769		Ansi 150	357	243	14.1	
S486BHC69	S586AHC69	SR120401S	KCF073891	DN65	Ansi 300	372	259.4	16.6	107
S485BHC70	S585AHC70	SR120401S	KCF073765		Ansi 150	372	279.4	23.0	
S486BHC70	S586AHC70	SR180401S	KCF103892	DN80	Ansi 300	436	297	27.9	120
S485BHC71	S585AHC71	SR180401S	KCF103770		Ansi 150	436	298	30.7	
S486BHC71	S586AHC71	SR240401S	KCF103892	DN100	Ansi 300	456	316	34.8	167
S485BHC72	S585AHC72	SR360401S	KCF123778		Ansi 150	566	365	58.5	
S486BHC72	S586AHC72	SR480401S	KCF123905	DN125	Ansi 300	602	385.2	67.3	180
S485BHC73	S585AHC73	SR480401S	KCF123778		Ansi 150	602	387.2	67.4	
S485BHC74	S585AHC74	SR720401S	KCF163901	DN150	Ansi 150	834	613	173.3	240
S485BHC75	S585AHC75	SR1440E16D8A	KCF163903	DN200	Ansi 150	975	622.5	267	314

ATTUATORE ELETTRICO ON-OFF <i>ELECTRIC ACTUATOR ON-OFF</i>									
PN 16-40									
CORPO/BODY STAINLESS STEEL	CORPO/BODY CARBON STEEL	ATTUATORE actuator	KIT di montaggio connecting kit	MISURA size	PN	N	H	Kg	L
C486BA5E064	C586AA5E064	EA0035A5C000	KCF053775	DN15	16-40	250	209	5.7	53
C486BA5E065	C586AA5E065	EA0035A5C000	KCF053775	DN20	16-40	250	212	6.2	53
C486BA5E066	C586AA5E066	EA0035A5C000	KCF053768	DN25	16-40	250	219	7.1	58
C486BA5G067	C586AA5G067	EA0070A5C000	KCF053768	DN32	16-40	250	224	8.8	65
C486BA5G068	C586AA5G068	EA0070A5C000	KCF053764	DN40	16-40	250	245	11.1	79
C486BA5I069	C586AA5I069	EA0130A5C000	KCF073769	DN50	16-40	280	274.6	17.0	90
C485BA5I070	C585AA5I070	EA0130A5C000	KCF073765	DN65	16	280	300.6	23.9	107
C486BA5K070	C586AA5K070	EA0240A5C000	KCF103770		25-40	280	300.6	23.6	
C486BA5K071	C586AA5K071	EA0240A5C000	KCF103770	DN80	16-40	280	307.6	27.7	120
E485B16N072	E585A16N072	AE160040	KCE363779	DN100	16	256.5	372	50.9	167
E486B16N072	E586A16N072				25-40	256.5	372	51.0	
E485B16N073	E585A16N073	AE160040	KCE363779	DN125	16	256.5	382	58.7	180
E486B16R073	E586A16R073	AE160060	KCE563907		25-40	381	439	81	
E485B16R074	E585A16R074	AE160060	KCE563908	DN150	16	381	488	132	240
E485B16T075	E585A16T075	AE1600100	KCE563909	DN200	16	381	522	205	314

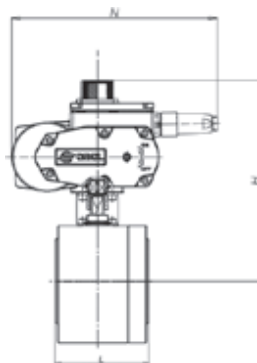

ATTUATORE ELETTRICO ON-OFF <i>ELECTRIC ACTUATOR</i>									
ANSI 150-300									
CORPO/BODY STAINLESS STEEL	CORPO/BODY CARBON STEEL	ATTUATORE actuator	KIT di montaggio connecting kit	MISURA size	ANSI	N	H	Kg	L
C485BA5EC64	C585AA5EC64	EA0035A5C000	KCF053775	DN15	Ansi 150	250	209	5.7	53
C486BA5EC64	D586AA5EC64		KCF053894		Ansi 300	250	211	5.7	
C485BA5EC65	C585AA5EC65	EA0035A5C000	KCF053775	DN20	Ansi 150	250	212	6.1	53
C486BA5EC65	C586AA5EC65		KCF053895		Ansi 300	250	216	6.7	
C485BA5EC66	C585AA5EC66	EA0035A5C000	KCF053768	DN25	Ansi 150	250	219	7.0	58
C486BA5EC66	C586AA5EC66		KCF053896		Ansi 300	250	222	7.4	
C485BA5EC67	C585AA5EC67	EA0070A5C000	KCF053768	DN32	Ansi 150	250	224	8.8	65
C486BA5EC67	C586AA5EC67		KCF053764		Ansi 300	250	224	8.8	
C485BA5GC68	C585AA5GC68	EA0070A5C000	KCF053764	DN40	Ansi 150	250	245	11.1	79
C486BA5GC68	C585AA5GC68		KCF073769		Ansi 300	250	245	12.2	
C485BA5IC69	C585AA5IC69	EA0130A5C000	KCF073769	DN50	Ansi 150	280	274.6	17.1	90
C486BA5IC69	C586AA5IC69		KCF073891		Ansi 300	280	280.6	19.5	
C485BA5IC70	C585AA5IC70	EA0130A5C000	KCF073765	DN65	Ansi 150	280	300.6	24.0	107
C486BA5KC70	C586AA5KC70		EA0240A5C000		KCF103892	Ansi 300	280	306.6	
C485BA5KC71	C585AA5KC71	EA0240A5C000	KCF103770	DN80	Ansi 150	280	307.6	28.2	120
C486BA5KC71	C586AA5KC71		KCF103892		Ansi 300	280	313.6	31.5	
E485B16NC72	E585A16NC72	AE160040	KCE363779	DN100	Ansi 150	256.5	372	51.2	167
E486B16NC72	E586A16NC72		KCE363906		Ansi 300	256.5	380	58.7	
E485B16NC73	E585A16NC73	AE160040	KCE363779	DN125	Ansi 150	256.5	382	58.8	180
E485B16RC74	E585A16RC74	AE160060	KCE563908	DN150	Ansi 150	381	488	133	240
E485B16TC75	E585A16TC75	AE160100	KCE563909	DN200	Ansi 150	381	522	207	314