



Technical Data Sheet Type 1/041PN



Type 1/041PN

2/2-way pressure operating valve
 NC - Valve normally closed (as standard)
 NO - Valve normally open (as option)

Force-pilot operated piston design valve. No differential pressure is necessary for operation. In standard (NC) the valve closes with spring power.

■ **Pressure controlled valve for high pressure applications**

TECHNICAL SPECIFICATIONS

Type of control	Force-pilot pressure operated
Design	Piston design
Connection	Threaded G1/4 - G2 Flanged DN15 - DN100
Installation	Preferable with actuator upright
Pressure	0 - 100 bar (see table on page 2)
Medium	Clean, neutral, gaseous and liquid media
max. viscosity	50 mm ² /s
Temperature range	Medium: -40 °C up to +200 °C Ambient: -10 °C up to +60 °C
Body material	Brass 2.0402 Stainless steel .4408
Metallic inner parts	Brass and Stainless steel
Sealing	PTFE
Pilot pressure	4 - 10 bar max pressure with at least 6 bar
Pilot medium	Clean and neutral gases Other pilot media on request
Pilot valve	2/131-31-1702-C182



3/2-way direct operated, NC
 G1/8, orifice 1.5mm, 0-8 bar
 Aluminum / Stainless steel / FKM
 with Cnomo-coil as well as with
 integrated screw connection for easy
 assembly

A7231/1002/....



3/2-way direct operated, NC
 G1/8, orifice 1.5mm, 0-8 bar
 Brass / Stainless steel / FKM

VALVE FEATURES

- For high pressure applications up to 100 bar
- No pressure difference required
- High life time
- High-quality materials
- Reliable and sturdy sealing elements
- Pneumatic actuator on request

FUNCTION

NC – non pressurized closed NO – non pressurized open

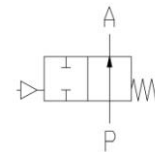
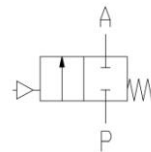

CERTIFICATES



ORDERING SYSTEM

Type	Connect.	Housing	Seal	Actuator
1 / 0 4 1	- 2 5 -	1 0 0 4	-	7 0 0 8
	21 G 1/4 22 G 3/8 23 G 1/2 24 G 3/4 25 G 1 26 G 1 1/4 27 G 1 1/2 28 G 2	00 Steel C22.8 08 St. steel 1.4408 10 Brass 2.0401	04 PTFE	7 . Normally closed 8 . Normally open 9 . Double acting . 0 Standard actuator . 3 Act. Stainless steel . 5 Act. chem. nickel pl. . 8 80 mm . 3 125 mm

TECHNICAL FEATURES

Type 1/041PN

G	Seat Ø mm	Kv-value m³/h	Standard type	max. pressure with actuator	
				7008	7013
1/4	13	1,8	1/041-21-..04-	0-100	-
3/8	13	3,3	1/041-22-..04-	0-100	-
1/2	13	3,8	1/041-23-..04-	0-100	-
3/4	25	11,5	1/041-24-..04-	0-100	-
1	25	13,0	1/041-25-..04-	0-100	-
1 1/4	32	22,0	1/041-26-..04-	0-100	-
1 1/2	40	24,0	1/041-27-..04-	0-100	-
2	50	32,0	1/041-28-..04-	0-100	-

DN	Seat Ø mm	Kv-value m³/h	Standard type	max. pressure with actuator	
				7008	7013
15	15	3,8	1/041-01-..04-	0-100	-
20	20	11,0	1/041-02-..04-	0-100	-
25	25	13,0	1/041-03-..04-	0-100	-
32	32	22,0	1/041-04-..04-	0-100	-
40	40	24,0	1/041-05-..04-	0-100	-
50	50	35,0	1/041-06-..04-	0-100	-
65	65	68,0	1/041-07-..04-	0-64	0-100
80	80	85,0	1/041-08-..04-	0-64	0-100
100	100	120,0	1/041-09-..04-	0-64	0-100

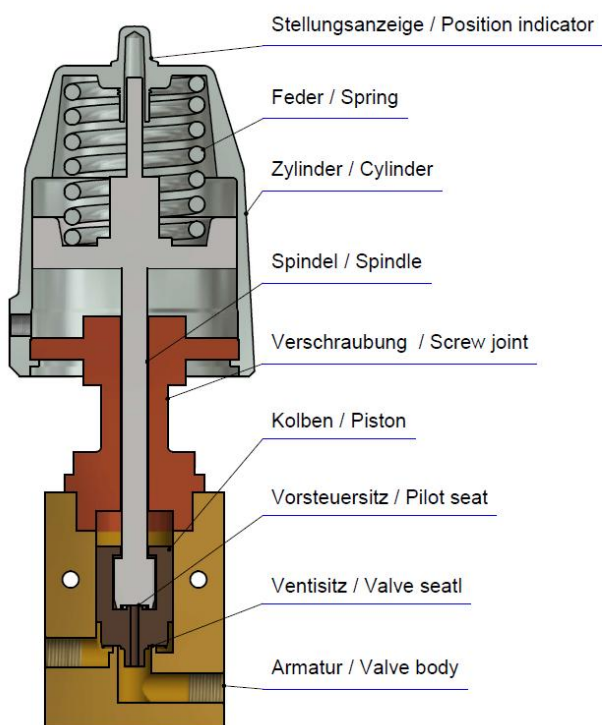

DIMENSIONS

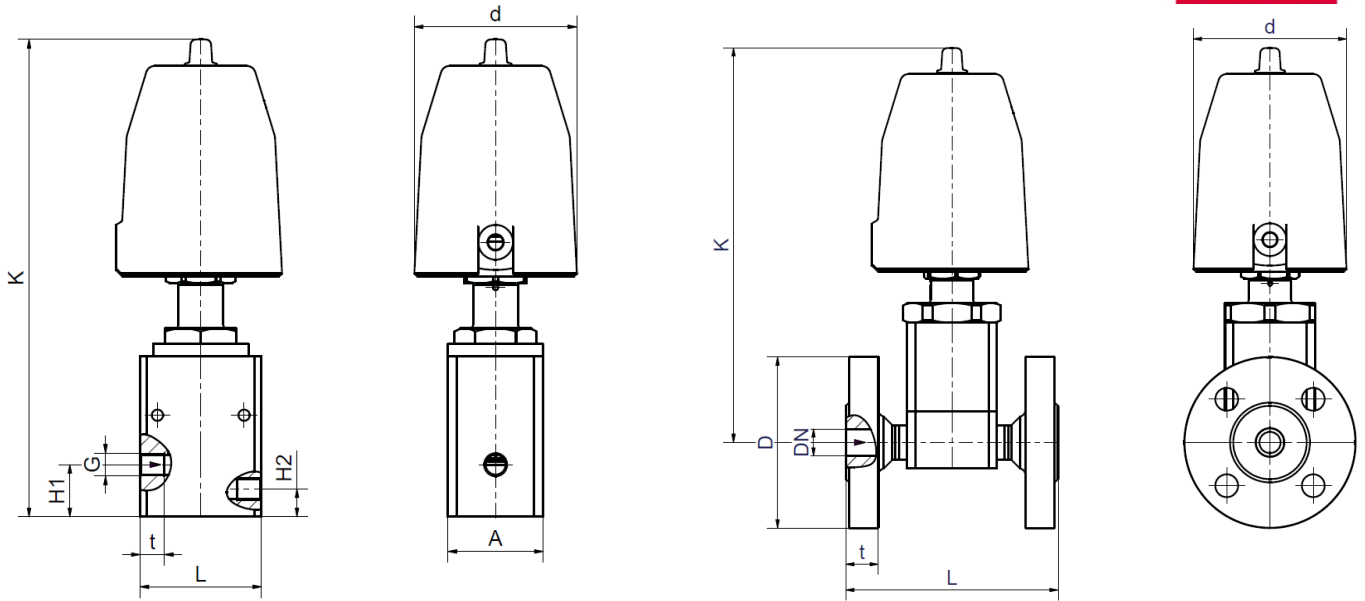

Actuator	7008			
Type	1/041-21(-23)	1/041-24(-25)	1/041-26(-27)	1/041-28
G	1/4 - 1/2	3/4 - 1	1 1/4 - 1 1/2	2
d	94	94	94	94
H1	30	45	33	38,5
H2	16	25	33	38,5
K	276	309	308	346
A	55	65	96	119
L	70	100	140	168
t	14	17	22	24
kg	4,3	7,7	17,0	16,6

Actuator	7008								
Type	1/041-01	1/041-02	1/041-03	1/041-04	1/041-05	1/041-06	1/041-07	1/041-08	1/041-09
DN	15	20	25	32	40	50	65	80	100
d	94	94	94	94	94	94	94	94	94
D	105	130	140	on req.	170	on req.	on req.	230	265
K	243	257	257	on req.	278	on req.	on req.	358	408
L	130	230	230	on req.	220	on req.	on req.	300	430
t	20	24	24	24	28	26	34	36	40
kg	5,7	12,0	12,6	on req.	17,1	on req.	on req.	84,5	108,0

Dimensions with actuator 7013 on request

INFORMATION

- It is imperative to observe the installation and safety instructions in our operating and service manuals.
- For information on our GSR ordering code, please refer to our catalogs. If you have any questions, we will be glad to assist you.
- Required ordering information: valve type, function NC/NO, pressure range, connection, nominal width, medium, flow rate, medium and ambient temperatures, connection voltage.
- **Detailed production-specific drawings and other technical information will be made available when an order is placed**

PLEASE NOTE

Each individual application decides which valve type is required, the main factor being the resistance of the materials to the operating medium. The correct selection of materials requires knowledge of the concentration, temperature and degree of contamination of the medium. Other criteria include the operating pressure and max. volumetric flow, since , in addition to high temperatures , high pressures and high flow rates must also be taken into account when selecting the materials.

All materials used for our valves, be it housing, seals or magnets, will be carefully selected in view of the different application areas. Any information given is non-binding and serves for orientation only. No claims under warranty can be derived therefrom.

- The GSR logo is a registered trademark of GSR Ventiltechnik GmbH & Co. KG.
- Note: All texts and images are the property of GSR Ventiltechnik GmbH & Co. KG and must not be replicated or modified, not even in part, without written approval.
- Original products may differ from the product images shown, due to different materials and the like.
- Subject to error and changes.

Stand: 01.18, MK-MG, Version 1.