



# Technical Data Sheet Type 2/640



Type 2/640

- 2/2-way pressure operated valve
- NC - Valve normally closed (as standard)
- NO - Valve normally open (as option)
- DW - Valve with double acting actuator (as option)

Pressure operated valve, poppet design.

■ **Valve for extended temperature range**

## TECHNICAL SPECIFICATIONS

Type of control	DN15-DN50: direct operated DN65-DN100: force-pilot operated
Design	Poppet design
Connection	Threaded G 1/4 - G 2 DIN ISO 228/1 (BSP) Flanges DN15 - DN100 EN 1092-1 Form B1
Installation	Preferable with actuator upright
Pressure	0 - 40 bar (see table on page 2)
Medium	Clean, neutral, gaseous and liquid media
Viscosity	600 mm <sup>2</sup> /s
Temperature range	Medium: -40 °C up to +400 °C Ambient: -40 °C up to +60 °C
Body material	Stainless steel 1.4408 / 1.4571 Cast steel GP240 GH
Metallic inner parts	Stainless steel
Sealing	Metallic, static Wills-Ring
Pilot pressure	4 - 10 bar
Pilot medium	Clean and neutral gases Other pilot media on request

Pilot valve	<b>2/131-31-1702-C182</b>
-------------	---------------------------



3/2-way direct operated, NC  
G1/8, orifice 1.5mm, 0-8 bar  
Aluminum / Stainless steel /FKM  
with Cnomo-coil as well as with  
integrated screw connection for  
easy assembly.

	<b>A7231/1002/....</b>
--	------------------------



3/2-way direct operated, NC  
G1/8, orifice 1.5mm, 0-8 bar  
Brass / Stainless steel / FKM

## VALVE FEATURES

- For media temperatures up to +400 °C
- No pressure difference required
- High life time
- Long-term availability of spare parts
- NO - non-pressurized open as option
- DW - double acting as option

## FUNCTION

NC – non  
pressurized  
closed

NO – non  
pressurized open

DW - double  
acting

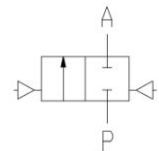
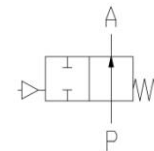
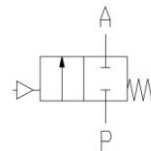

## CERTIFICATES



## ORDERING SYSTEM

Type	Connect.	Housing	Seal	Actuator	Option
2 / 6 4 0	- 2 3	- 0 8 0 0	-	- 7 0 0 8	- D T
21 G 1/4	05 GP240 GH	7 . Normally closed		. 5 50 mm	DT Distance unit
22 G 3/8	08 Stainl.st. 1.4571	8 . Normally open		. 8 80 mm	FL Flanged
23 G 1/2		9 . Double acting		. 3 125 mm	
24 G 3/4			00 metallic		
25 G 1					
26 G 1 1/4					
27 G 1 1/2					
28 G 2					
07 DN65					
08 DN80					
09 DN100					

# TECHNICAL FEATURES

G DN	Seat Ø mm	Kv-value m³/h	Standard type	max. pressure for actuator		
				7.05	7.08	7.13
1/4	15	1,6	2/640-21-0800-	0-10	0-16	-
3/8	15	3,3	2/640-22-0800-	0-10	0-16	-
1/2	15	4,6	2/640-23-0800-	0-10	0-16	0-40
3/4	20	6,4	2/640-24-0800-	-	0-16	0-40
1	25	9,5	2/640-25-0800-	-	0-16	0-40
1 1/4	32	21,5	2/640-26-0800-	-	0-10	0-25
1 1/2	40	27,0	2/640-27-0800-	-	0-10	0-25
2	50	46,0	2/640-28-0800-	-	0-6	0-16
65	65	62,0	2/640-07-0800-	-	0-16	0-40
80	80	89,0	2/640-08-0800-	-	0-16	0-40
100	100,0	125,0	2/640-09-0800-	-	0-16	0-40

DN15 - DN50: Direct operated

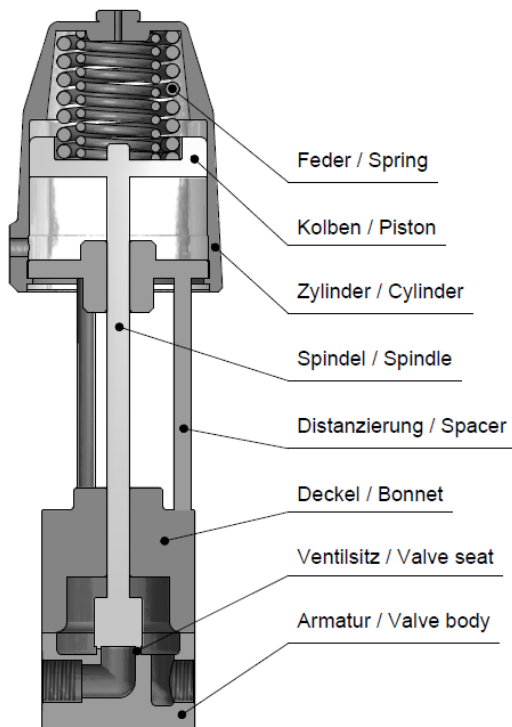

DN65 - DN100: Force-pilot operated

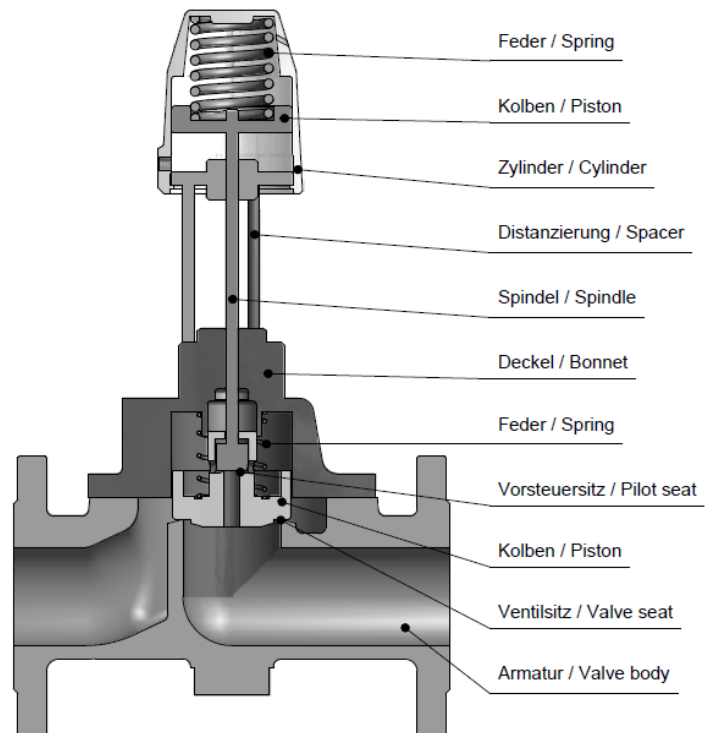

# DIMENSIONS

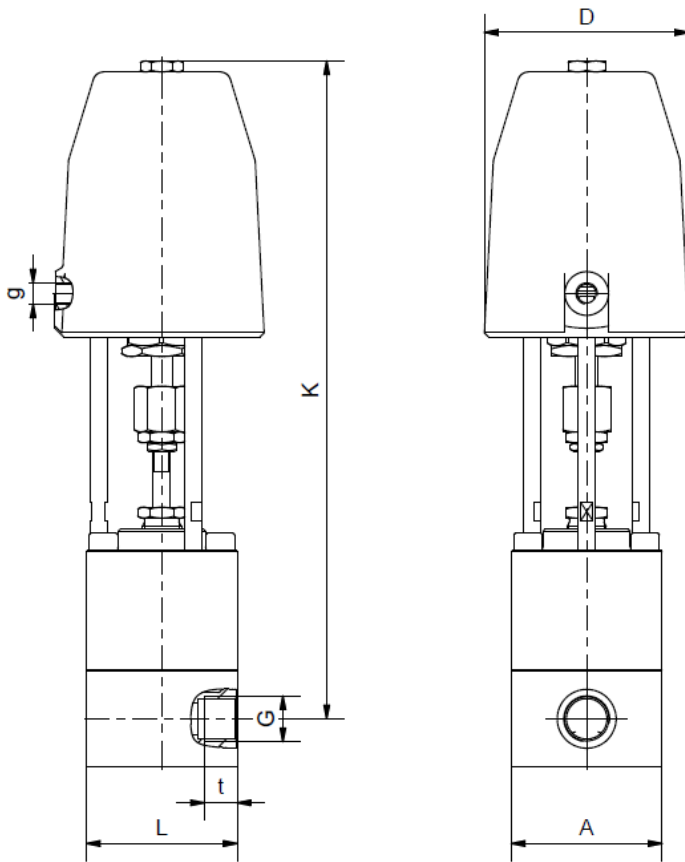

Actuator	7.05			7008							
Type	2/640-21	2/640-22	2/640-23	2/640-21	2/640-22	2/640-23	2/640-24	2/640-25	2/640-26	2/640-27	2/640-28
G	1/4	3/8	1/2	1/4	3/8	1/2	3/4	1	1 1/4	1 1/2	2
A	50	50	50	69	69	69	69	95	96	96	112
D	62	62	62	94	94	94	94	94	94	94	94
K	239	239	239	302	302	302	307	305	340	340	355
L	67	67	67	69	69	69	69	69	140	140	168
t	12	12	12	15	15	15	15	16	20	20	22
g	1/8	1/8	1/8	1/8	1/8	1/8	1/8	1/8	1/8	1/8	1/8
kg	2,7	2,7	2,7	5,0	5,0	5,0	5,0	5,7	on req.	on req.	on req.

Actuator	7013				
Type	2/640-24	2/640-25	2/640-26	2/640-27	2/640-28
G	3/4	1	1 1/4	1 1/2	2
A	69	95	95	95	112
D	140	140	140	140	140
K	382	380	420	420	435
L	69	69	140	140	168
t	15	16	20	20	22
g	1/4	1/4	1/4	1/4	1/4
kg	7,0	7,7	on req.	on req.	on req.

## DIMENSIONS

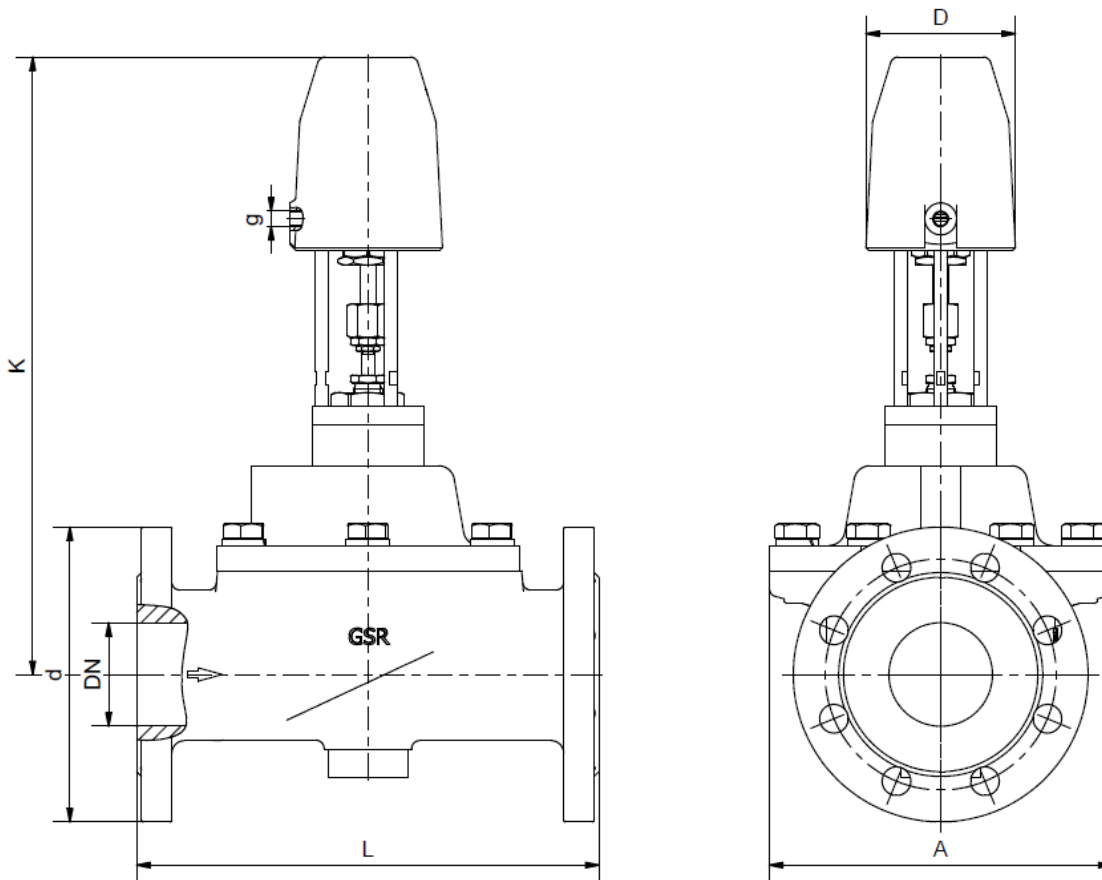

Actuator	7.05					7008				
Type	2/640-23	2/640-23	2/640-24	2/640-25	2/640-26	2/640-27	2/640-28	2/640-07	2/640-08	2/640-09
DN	15	15	20	25	32	40	50	65	80	100
A	44	44	69	69	96	96	112	215	245	270
d	95	95	105	115	140	150	165	185	200	220
D	62	94	94	94	94	94	94	94	94	94
K	239	302	307	305	340	340	355	390	395	420
L	130	130	150	160	180	200	230	290	310	350
g	1/8	1/8	1/8	1/8	1/8	1/8	1/8	1/8	1/8	1/8
kg	on req.	on req.	on req.	on req.	on req.	on req.	on req.	26,5	35,0	47,0

Actuator	7013							
Type	2/640-24	2/640-25	2/640-26	2/640-27	2/640-28	2/640-07	2/640-08	2/640-09
DN	20	25	32	40	50	65	80	100
A	69	69	96	96	112	215	245	270
d	105	115	140	150	165	185	200	235
D	140	140	140	140	140	140	140	140
K	282	380	420	420	435	470	480	500
L	150	160	180	200	230	290	310	350
g	1/4	1/4	1/4	1/4	1/4	1/4	1/4	1/4
kg	on req.	on req.	on req.	on req.	on req.	on req.	on req.	on req.

## INFORMATION

- It is imperative to observe the installation and safety instructions in our operating and service manuals.
- For information on our GSR ordering code, please refer to our catalogs. If you have any questions, we will be glad to assist you.
- Required ordering information: valve type, function NC/NO, pressure range, connection, nominal width, medium, flow rate, medium and ambient temperatures, connection voltage.
- **Detailed production-specific drawings and other technical information will be made available when an order is placed**

## PLEASE NOTE

Each individual application decides which valve type is required, the main factor being the resistance of the materials to the operating medium. The correct selection of materials requires knowledge of the concentration, temperature and degree of contamination of the medium. Other criteria include the operating pressure and max. volumetric flow, since , in addition to high temperatures , high pressures and high flow rates must also be taken into account when selecting the materials.

**All materials used for our valves, be it housing, seals or magnets, will be carefully selected in view of the different application areas. Any information given is non-binding and serves for orientation only. No claims under warranty can be derived therefrom.**

- The GSR logo is a registered trademark of GSR Ventiltechnik GmbH & Co. KG.
- Note: All texts and images are the property of GSR Ventiltechnik GmbH & Co. KG and must not be replicated or modified, not even in part, without written approval.
- Original products may differ from the product images shown, due to different materials and the like.
- Subject to error and changes.

**Stand: 05.17, MK-MG, Version 1.**