

# Technical Data Sheet Type 63DT



2/2-way pressure operated valve  
 NC - Valve normally closed (as standard)  
 NO - Valve normally open (as option)

Direct pressure controlled valve. The valve seat is opened against a spring force via the control medium.

■ **Valve for extended temperature range**

## TECHNICAL SPECIFICATIONS

Type of control	Direct-pressure operated
Design	poppet design
Connection	Threaded G 1/2 - G 3 DIN ISO 228/1 (BSP)
Installation	Preferable with actuator upright
Pressure	0 - 40 bar (see table on page 2)
Medium	Clean, neutral, gaseous and liquid media
Viscosity	600 mm <sup>2</sup> /s
Temperature range	Medium: -40 °C up to +250 °C Ambient: -10 °C up to +60 °C
Body material	Red brass RG5 Stainless steel 1.4408 / 1.4571
Metallic inner parts	Red brass, brass, stainless steel
Sealing	PEEK
Pilot pressure	4 - 10 bar max pressure with at least 6 bar
Pilot medium	Clean and neutral gases Other pilot media on request

Pilot valve	<b>2/131-31-1702-C182</b>
-------------	---------------------------



3/2-way direct operated, NC  
 G1/8, orifice 1.5mm, 0-8 bar  
 Aluminum / Stainless steel /FKM  
 with Cnomo-coil as well as with  
 integrated screw connection for  
 easy assembly.

	<b>A7231/1002/....</b>
--	------------------------



3/2-way direct operated, NC  
 G1/8, orifice 1.5mm, 0-8 bar  
 Brass / Stainless steel / FKM

## VALVE FEATURES

- For media temperatures up to +250 °C
- No pressure difference is required
- High life time
- Simple compact valve design
- High-quality materials
- Reliable and sturdy sealing elements

## FUNCTION

NC – non pressurized closed    NO – non pressurized open

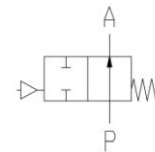
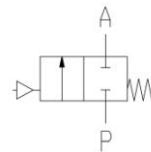

## CERTIFICATES



Special design available for temperatures **up to +300 °C**.  
 Specifications and drawings on request.

## ORDERING SYSTEM

Type	Conn.	Housing	Seal	Actuator	Option
. 6 3	2 3	/ 1 1	1 5 /	7 1 0 5	- D T
	23 G 1/2 24 G 3/4 25 G 1 26 G 1 1/4 27 G 1 1/2 28 G 2 29 G 2 1/2 30 G 3	08 Stainl. st. 1.4408 10 Brass 2.0402 11 Red brass RG5	15 PEEK	7 . Normally closed 8 . Normally open . 1 Standard actuator . 3 Act. Stainless steel . 5 Act. chem. nickel pl.	DT Distance unit +250°C medium
				. 5 50 mm . 8 80 mm . 3 125 mm	

# TECHNICAL FEATURES

				max. pressure with actuator					
G	Seat Ø mm	Kv-value m³/h	Standard type	7.05		7.08		7.13	
				Red brass	Stainless steel	Red brass	Stainless steel	Red brass Brass	Stainless steel
1/2	13	4,6	.6323/..15/7...-DT	0-16	0-40	-	-	-	-
3/4	18	6,4	.6324/..15/7...-DT	0-16	0-20	-	0-40	-	-
1	24	8,4	.6325/..15/7...-DT	0-16	0-16	0-16	0-25	-	0-40
1 1/4	31	21,5	.6326/..15/7...-DT	0-9	0-9	0-16	0-25	-	0-40
1 1/2	35	27,0	.6327/..15/7...-DT	0-7	0-7	0-16	0-20	0-16	0-40
2	45	45,0	.6328/..15/7...-DT	-	-	0-11	0-12	0-16	0-25
2 1/2	63	82,0	.6329/..15/7...-DT	-	-	-	-	0-10	-
3	76	125,0	.6330/..15/7...-DT	-	-	-	-	0-10	-

				max. pressure for design closing against the flow					
G	Seat Ø mm	Kv-value m³/h	Standard type	7.15 / 7.55		7.58		7.63	
				Red brass	Stainless steel	Red brass	Stainless steel	Red brass Brass	Stainless steel
1/2	13	4,6	.6323/..15/7...-DT	0-16	0-40	-	-	-	-
3/4	18	6,4	.6324/..15/7...-DT	0-16	0-20	-	0-25	-	-
1	24	8,4	.6325/..15/7...-DT	0-8	0-10	0-16	0-22	-	0-40
1 1/4	31	21,5	.6326/..15/7...-DT	0-7	0-7	0-12	0-10	0-16	0-40
1 1/2	35	27,0	.6327/..15/7...-DT	0-6	0-6	0-8	0-8	0-16	0-30
2	45	45,0	.6328/..15/7...-DT	-	-	0-5	0-5	0-16	0-20
2 1/2	63	82,0	.6329/..15/7...-DT	-	-	-	-	0-8,5	-
3	76	125,0	.6330/..15/7...-DT	-	-	-	-	0-5	-

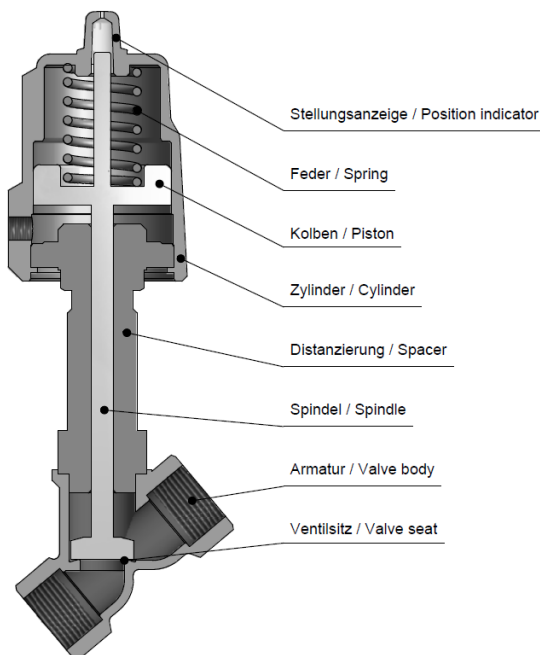

## DIMENSIONS

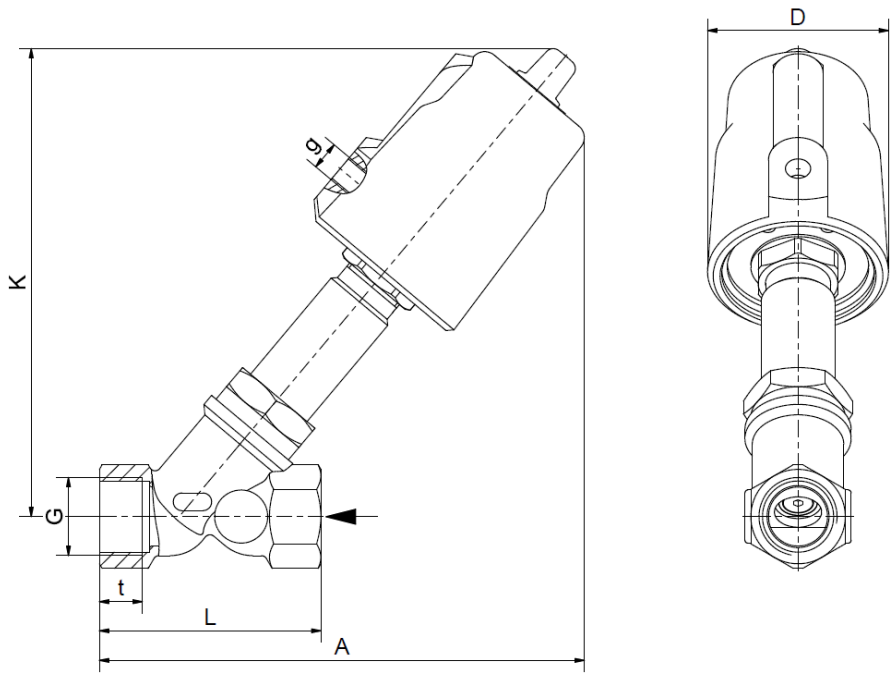

Actuator	7.05					7.08		
Type	6323	6324	6325	6326	6327	6324	6325	6326
G	1/2	3/4	1	1 1/4	1 1/2	3/4	1	1 1/4
A	158	165	170	188 (195)	200	(193)	208	217
D	62	62	62	62	62	(94)	94	94
K	158	161	164	180	187	(193)	208	217
L	65	75	90	97 (110)	120	(75)	80	97
g	1/8	1/8	1/8	1/8	1/8	(1/8)	1/8	1/8
t	12	14,5 (13)	15	12,5 (17)	19	(13)	10,5	12,5
kg	1,4	1,5	1,9	2,4	2,7	(1,7)	2,0	2,5

Values in brackets refer to the standard sealing material for stainless steel version

Actuator	7.08		7.13					
Type	6327	6328	6325	6326	6327	6328	6329	6330
G	1 1/2	2	1	1 1/4	1 1/2	2	2 1/2	3
A	224	235	a.Anf.	(275)	280	385	330	350
D	94	94	(140)	(140)	140	140	140	140
K	218	229	a.Anf.	(275)	280	285	300	305
L	107	124	(80)	(110)	107	124	178	195
g	1/8	1/8	(1/4)	(1/4)	1/4	1/4	1/4	1/4
t	14,5	16,5	(10,5)	(17)	14,5	16,5	28	28
kg	2,9	3,2	a.Anf.	(5,0)	5,5	6,5	8,0	9,5

Values in brackets refer to the standard sealing material for stainless steel version

## INFORMATION

- It is imperative to observe the installation and safety instructions in our operating and service manuals.
- For information on our GSR ordering code, please refer to our catalogs. If you have any questions, we will be glad to assist you.
- Required ordering information: valve type, function NC/NO, pressure range, connection, nominal width, medium, flow rate, medium and ambient temperatures, connection voltage.
- **Detailed production-specific drawings and other technical information will be made available when an order is placed**

## PLEASE NOTE

Each individual application decides which valve type is required, the main factor being the resistance of the materials to the operating medium. The correct selection of materials requires knowledge of the concentration, temperature and degree of contamination of the medium. Other criteria include the operating pressure and max. volumetric flow, since , in addition to high temperatures , high pressures and high flow rates must also be taken into account when selecting the materials.

**All materials used for our valves, be it housing, seals or magnets, will be carefully selected in view of the different application areas. Any information given is non-binding and serves for orientation only. No claims under warranty can be derived therefrom.**

- The GSR logo is a registered trademark of GSR Ventiltechnik GmbH & Co. KG.
- Note: All texts and images are the property of GSR Ventiltechnik GmbH & Co. KG and must not be replicated or modified, not even in part, without written approval.
- Original products may differ from the product images shown, due to different materials and the like.
- Subject to error and changes.

**Stand: 05.18, MK-MG, Version 1.**