



Technical Data Sheet Type 90



- 2/2-way pressure operating valve
- NC - Valve normally closed (as standard)
- NO - Valve normally open (as option)
- DW - Valve with double acting actuator (as option)

Direct pressure controlled valve. The valve seat is opened against a spring force via the control medium.

■ Valve for cryonic fluids

Type 90

TECHNICAL SPECIFICATIONS

Type of control	Pressure operated
Design	Poppet design
Connection	Threaded DIN ISO 228/1 Welding ends Further connections like NPT on request
Installation	With actuator upright
Pressure	0 - 16 bar and 0 - 40 bar (see table on page 2)
Medium	Clean, neutral, gaseous and liquid media
max. viscosity	600 mm ² /s
Temperature range	Medium: -196 °C up to +60 °C Ambient: -10 °C up to +60 °C
Body material	PN16: Stainless steel 1.4581 PN50: Stainless steel 1.4404
Metallic inner parts	Stainless steel
Sealing	PCTFE
Pilot pressure	4 - 10 bar max pressure with at least 6 bar
Pilot medium	Clean and neutral gases Other pilot media on request

Pilot valve	2/131-31-1702-C182
-------------	---------------------------



3/2-way direct operated, NC
G1/8, orifice 1.5mm, 0-8 bar
Aluminum / Stainless steel / FKM
with Cnomo-coil as well as with
integrated screw connection for
easy assembly

	A7231/1002/....
--	------------------------



3/2-way direct operated, NC
G1/8, orifice 1.5mm, 0-8 bar
Brass / Stainless steel / FKM

VALVE FEATURES

- For cryogenic media to -196 °C
- No pressure difference is required
- High life time
- High-quality materials
- Reliable and sturdy sealing elements

FUNCTION

NC – non
pressurized
closed

NO – non
pressurized open

DW - double
acting

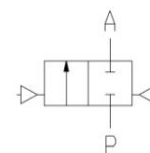
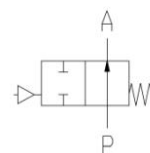
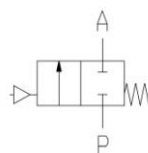

CERTIFICATES



ORDERING SYSTEM

Type	Conn.	Housing	Seal	Actuator	Option
B 9 0	2 3	/ 0 8	1 5	/ 7 5	0 5 - A S
A PN16	21 G 1/4				
B PN40	22 G 3/8	08 Stainless steel		7. Normally closed	
	23 G 1/2	1.4581 / 1.4404		8. Normally open	
	24 G 3/4		15 PCTFE	9. Double acting	
	25 G 1			.1 Standard actuator	
	26 G 1 1/4			.3 Act. Stainless steel	
	27 G 1 1/2			.5 Act. chem. nickel pl.	
	28 G 2				
					.5 50 mm
					.8 80 mm
					.3 125 mm

TECHNICAL FEATURES

G / DN	Seat Ø mm	Kv-value m³/h	Standard type	max. pressure with actuator					
				7.05		7.08		7.13	
				PN16	PN50	PN16	PN50	PN16	PN50
1/4	13,5	1,9	.9021/0815/	0-16	-	-	-	-	-
3/8	13,5	4,0	.9022/0815/	0-16	-	-	-	-	-
1/2 / 15	13,5	4,7	.9023/0815/	0-16	0-25	-	0-40	-	-
3/4 / 20	25	11,9	.9024/0815/	0-16	-	-	0-25	-	0-40
1 / 25	25	13,3	.9025/0815/	0-8	-	0-16	0-25	-	0-40
1 1/4 / 32	40	30,0	.9026/0815/	-	-	0-8	0-25	0-16	0-40
1 1/2 / 40	40	35,0	.9027/0815/	-	-	0-8	0-16	0-16	0-40
2 / 50	50	49,0	.9028/0815/	-	-	-	-	0-16	0-40

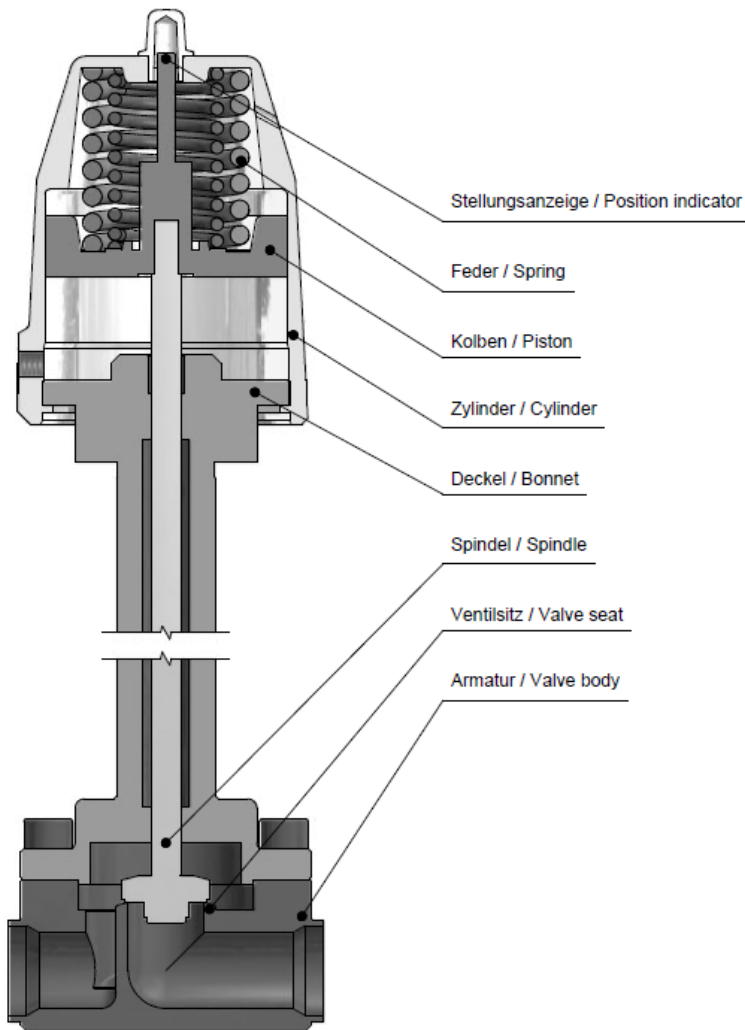

DIMENSIONS

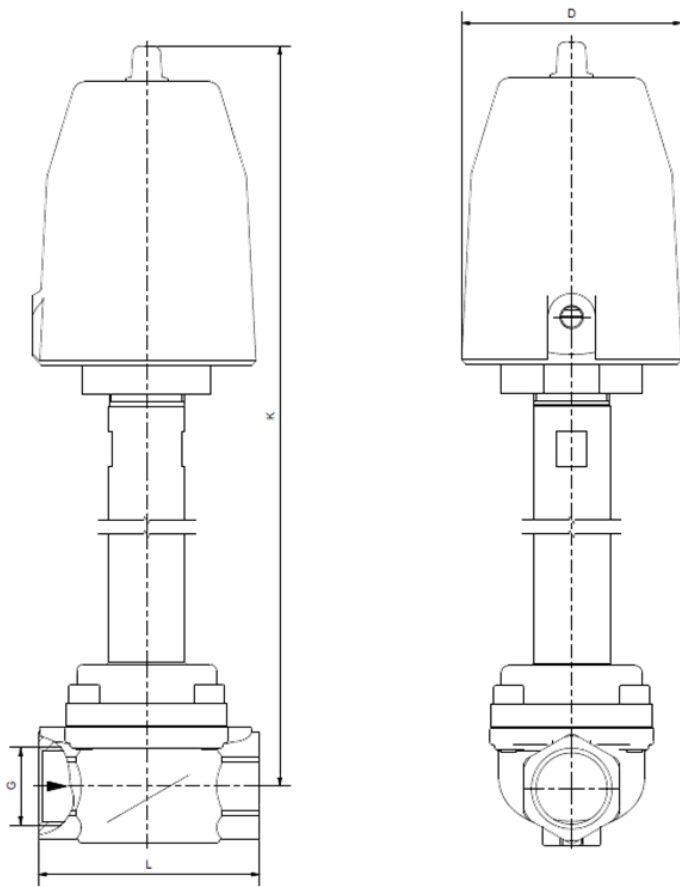

PN16

Actuator	7.05		7.08		7.13	
Type	A9021-23	A9024-25	A9024-25	A9026-27	A9026-27	A9028
G	1/4 - 1/2	3/4 - 1	3/4 - 1	1 1/4 - 1 1/2	1 1/4 - 1 1/2	2
K	400	410	440	470	535	545
L	67	96	96	140	140	168
D	62	62	94	94	145	145
kg	5,3	5,5	7,5	9,0	13,0	15,0

DIMENSIONS

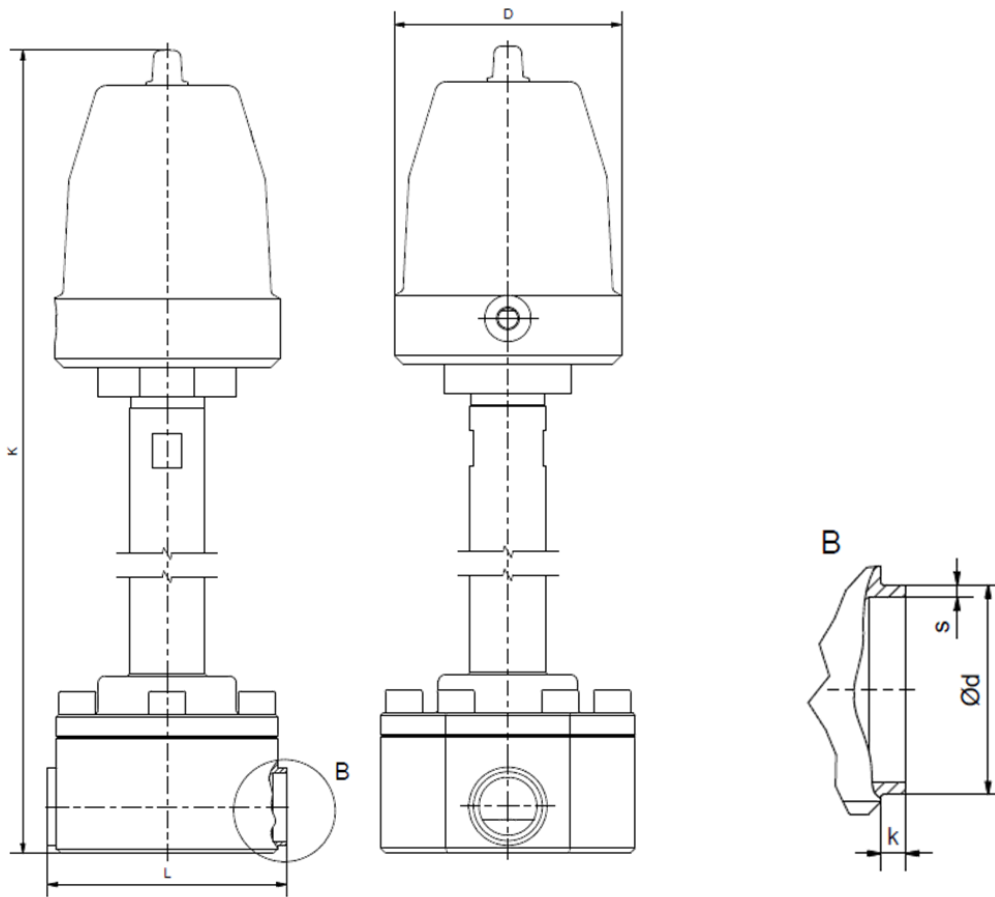

PN50

Actuator	7.05					7.08					7.13				
	B9023	B9024	B9025	B9026	B9027	B9024	B9025	B9026	B9027	B9028	B9024	B9025	B9026	B9027	B9028
Type	B9023	B9024	B9025	B9026	B9027	B9024	B9025	B9026	B9027	B9028	B9024	B9025	B9026	B9027	B9028
DN	13,5	25	27,5	40	40	40	40	40	40	50	40	40	40	40	50
K	400	440	440	470	470	505	505	535	535	545	505	505	535	535	545
L	80	104	102	148	147	104	102	148	147	178	104	102	148	147	178
D	62	94	94	94	94	145	145	145	145	145	145	145	145	145	145
d	24	30	36	45	52	30	36	45	52	65	30	36	45	52	65
s	3,5	4	4	5	5,5	4	4	5	5,5	5,5	4	4	5	5,5	5,5
k	2	4	4	4	3,5	4	4	4	3,5	4	4	4	3,5	4	4
kg	6,3	8,5	8,5	10,0	10,0	12,5	12,5	14,0	14,0	14,0	12,5	12,5	14,0	14,0	14,0

INFORMATION

- It is imperative to observe the installation and safety instructions in our operating and service manuals.
- For information on our GSR ordering code, please refer to our catalogs. If you have any questions, we will be glad to assist you.
- Required ordering information: valve type, function NC/NO, pressure range, connection, nominal width, medium, flow rate, medium and ambient temperatures, connection voltage.
- **Detailed production-specific drawings and other technical information will be made available when an order is placed**

PLEASE NOTE

Each individual application decides which valve type is required, the main factor being the resistance of the materials to the operating medium. The correct selection of materials requires knowledge of the concentration, temperature and degree of contamination of the medium. Other criteria include the operating pressure and max. volumetric flow, since , in addition to high temperatures , high pressures and high flow rates must also be taken into account when selecting the materials.

All materials used for our valves, be it housing, seals or magnets, will be carefully selected in view of the different application areas. Any information given is non-binding and serves for orientation only. No claims under warranty can be derived therefrom.

- The GSR logo is a registered trademark of GSR Ventiltechnik GmbH & Co. KG.
- Note: All texts and images are the property of GSR Ventiltechnik GmbH & Co. KG and must not be replicated or modified, not even in part, without written approval.
- Original products may differ from the product images shown, due to different materials and the like.
- Subject to error and changes.

Stand: 08.17, MK-MG, Version 1.