



VALVE TECHNOLOGY FOR
SHIPBUILDING



Innovative Valve Technology

VALVE TECHNOLOGY FOR SHIPBUILDING

In the shipbuilding industry, it is important that precise, highly developed components are used which operate with absolute reliability. For at sea it is not always possible to perform service tasks and the shore times in which such works could be done are continuously reduced.

The demands for marine components are also particularly high because the ambient conditions are often quite adverse. This included corrosion, vibrations and extreme temperatures.

Exactly for this demand, we offer a wide range of special valves from very different materials which are used in marine technology worldwide.



Type 2/449

Type 2/449

The start process of large diesel engines on ships demands, among other things, valves that let the engine start up reliably.

In this sensitive area of ship drives, valves of type 2/449 are often used. The solenoid valve switches the starting air from compressed air bottles into the starting system of the motor, thus initiating the starting process.

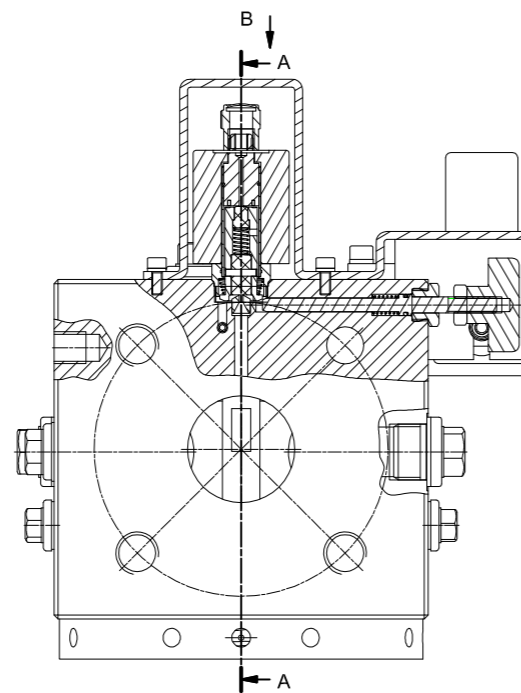

The 3/2 way pilot operated piston solenoid valve with customer-specific connections is designed for a pressure range of 7 to 40 bar. For the demanding applications in shipbuilding, the valve is equipped with additional options. This includes a red-anodized manual override for fast locating and switching off the valve. As a protection against foreign impact, the manual override is additionally equipped with a metal bracket.

Further options are a coupler socket with LED and a safety shutoff valve.

The valve has been designed from the start to prevent clogging of the pilot orifice even under most adverse conditions. The pilot orifice is very large, and a filter is installed in the valve. This prevents soiling from entering the valve there clogging the orifice.

Apart from further options, this valve is approved by the following classification organizations:

- | | | |
|--------|-------|------|
| ■ RINA | ■ ABS | ■ GL |
| ■ DNV | ■ BV | ■ LR |

In shipbuilding, our technically high quality valves designed per customer requirements are used in the following ranges of application, among others:

- Bilge water de-oilers
- Startup valve for diesel engines
- Water treatment
- Fire extinguishing systems



Type 2/425

Types 2/420 - 2/425

Due to the specific requirements in marine technology, our valve series 2/420 to 2/425 are used, among others.

The direct acting pressure controlled 2/2-way diaphragm valve (also available as 3/2-way valves under the type numbers 2/431 to 2/438) is designed for a pressure range up to 16 bar.

The body material is mainly cast iron, upon request also cast steel or stainless steel.

This valve is used as oil drain valve in bilge water de-oilers. Due to the sturdy diaphragm design, we can ensure extreme immunity in the media range and a high stability even under the most severe operating conditions.



Type 24

Type 24

The force pilot operated 2/2-way piston solenoid valve of the type 24, suitable for a pressure range of 0-40 bar, is used as component in a fire extinguishing system.

The valve has been specifically designed for the highly demanding customer application and is equipped with a manual override.

Additionally two position indicators can be offered.





Further valves with GL certification and special solutions on request.



Now also available with IP68.

Solenoid valves with GL approval for the shipbuilding industry



	Type	Design	Material	Size	Pressure range min/max	
	24	2/2-Way force pilot operated solenoid valve	Cast steel, Cast iron	DN15-DN100	0-40 bar	
	28	2/2-Way pilot operated solenoid valve	Cast iron	DN15-DN50	0.5-16 bar	
	40	2/2-Way pilot operated solenoid valve	Brass, Stainless steel	G ¹ / ₄ -G2	0.3-20 bar 0.5-16 bar	
	52	2/2-Way direct acting solenoid valve	Brass	G ¹ / ₈ -G ¹ / ₂	0-100 bar	
	72	3/2-Way direct acting solenoid valve	Brass	G ¹ / ₈ -G ¹ / ₄	0-20 bar	

On request, approvals for single valves according to RINA, BV, DNV, etc. available



GSR Ventiltechnik GmbH & Co. KG
 Im Meisenfeld 1 • D-32602 Vlotho
 P.O. Box 2060 • D-32595 Vlotho

Innovative Valve Technology

Copyright by GSR Ventiltechnik GmbH & Co. KG. All rights reserved. Duplication only with prior approval of GSR. State May 2012. Original products may vary from the product photographs due to deviating materials etc. Errors excepted, subject to change.