



# Technical Data Sheet Proportional valves 4R



2/2-way dosing valve

Pressure operated dosing valve with electro-pneumatic positioner for dosing applications

■ Dosing valve for gaseous and liquid media

Dosing valves 4R

## TECHNICAL SPECS CONTROLLER

Supply voltage:	24 VDC
Voltage tolerance:	-10% / +10%
Power consumption:	100 mA
Power:	2,4 Watt
Input signal:	4-20 mA (basic setting) optional 0-10 V (selectable by menu)
Output signal:	According to the input signal (selectable independent to the input signal)
Protection class:	IP65 acc. to DIN 60529
Connection of control medium:	G 1/8
Control medium:	Clean and neutral gases
Control pressure:	4 - 10 bar
Quality:	Compressed air class 3 (Medium quality acc. to ISO 8573-1)

## VALVE FEATURES

- Ideal for continuous media control
- Even in higher temperature ranges
- High dosing accuracy
- High control accuracy
- Three safety-setting-options: (open/closed/remain)
- No additional electronics required for adjustment
- CE acc. to EMV DIN EN 61000
- ROHS
- Reverse polarity protection

## FUNCTION

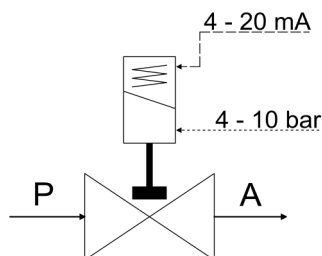

## CONTROL BEHAVIOR

Acquisition range:	0 - 23 mm
Resolution:	0,5% o. max. stroke
Repeat accuracy:	> 99%
Hysteresis:	< 1%
Responsiveness:	< 1%
Adjustment range:	1:200

The characteristic curve shown is valid for all nominal sizes and series.

The corresponding Kv values are shown in the table of the specific valve.

Characteristic determined according to VDI-VDE 2173

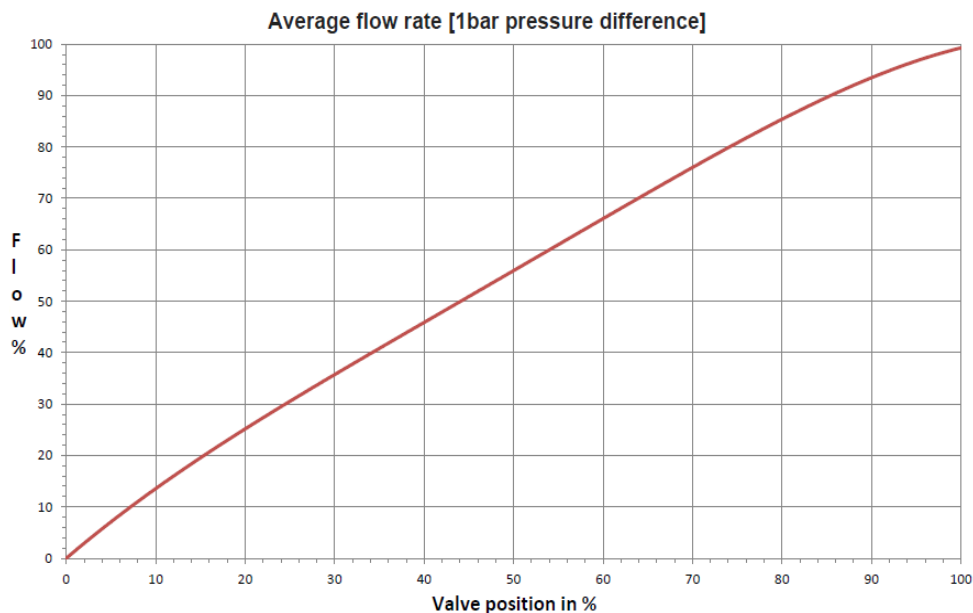

# Type 63-4R—ANGLE SEAT VALVES

## TECHNICAL FEATURES



Dosing valves 4R



Type of control:	Pressure operating dosing valve
Design:	Seat valve with cone-type piston
Connection:	Threaded G 1/4 - G 2 DIN ISO 228 (BSP) <i>Further connections like NPT on request</i>
Installation:	Preferable with actuator upright
Pressure range:	0 - 40 bar
Medium:	Clean, neutral, liquid or gaseous

Viscosity:	600 mm <sup>2</sup> /s
Temperature range:	Medium -40 °C bis +150 °C Ambient -10 °C bis +60 °C
Body material:	Red brass RG5 Stainless steel 1.4408
Metallic inner parts:	Brass and stainless steel
Sealing:	PTFE

Version with red brass body										
G	Type	Actuator	Seat mm	Pressure bar	Kv-value in m <sup>3</sup> /h at opening in %					
					10%	25%	50%	75%	100%	
1/2	.6323/1104/	7155-4R	12,5	0-16	0,6	1,4	2,4	3,2	3,6	
3/4	.6324/1104/	7115-4R	18,0	0-16	0,6	1,2	1,8	2,3	2,6	
1	.6325/1104/	7115-4R	23,5	0-10	0,3	0,8	1,4	2,0	2,4	
		7158-4R		0-16	0,8	2,1	3,9	5,4	6,2	
1 1/4	.6326/1104/	7158-4R	31,0	0-12	8,6	13,9	16,3	18,0	18,6	
		7163-4R		0-16	a.Anfr.	a.Anfr.	a.Anfr.	a.Anfr.	a.Anfr.	
1 1/2	.6327/1104/	7158-4R	35,0	0-8	10,7	17,1	21,0	24,0	25,0	
		7163-4R		0-16	10,7	18,0	22,2	24,3	26,1	
2	.6328/1104/	7158-4R	45,0	0-5	11,0	18,8	24,5	27,0	29,5	
		7163-4R		0-16	16,5	25,4	30,0	33,0	34,5	

Version with stainless steel body										
G	Type	Actuator	Seat mm	Pressure bar	Kv-value in m <sup>3</sup> /h at opening in %					
					10%	25%	50%	75%	100%	
1/2	.6323/0804/	7555-4R	12,5	0-40	0,6	1,2	1,9	2,6	3,0	
3/4	.6324/0804/	7515-4R	18,0	0-20	1,5	2,5	3,8	4,5	4,8	
1	.6325/0804/	7515-4R	23,5	0-10	1,5	2,5	3,8	4,7	5,4	
		7158-4R		0-22	3,4	6,1	8,8	9,7	10,3	
1 1/4	.6326/0804/	7158-4R	31,0	0-12	4,5	9,7	13,7	15,4	16,6	
		7163-4R		0-40	8,2	14,6	17,3	18,2	18,7	
1 1/2	.6327/0804/	7158-4R	35,0	0-8	8,7	16,6	21,6	23,4	24,6	
		7163-4R		0-30	10,8	18,9	22,3	23,6	24,7	
2	.6328/0804/	7158-4R	45,0	0-5	4,5	9,5	15,3	18,5	21,5	
		7163-4R		0-20	7,7	15,5	21,5	24,7	27,0	

# Type 63-4R—ANGLE SEAT VALVES DIMENSIONS



Dosing valves 4R

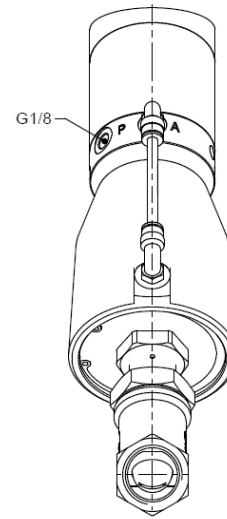
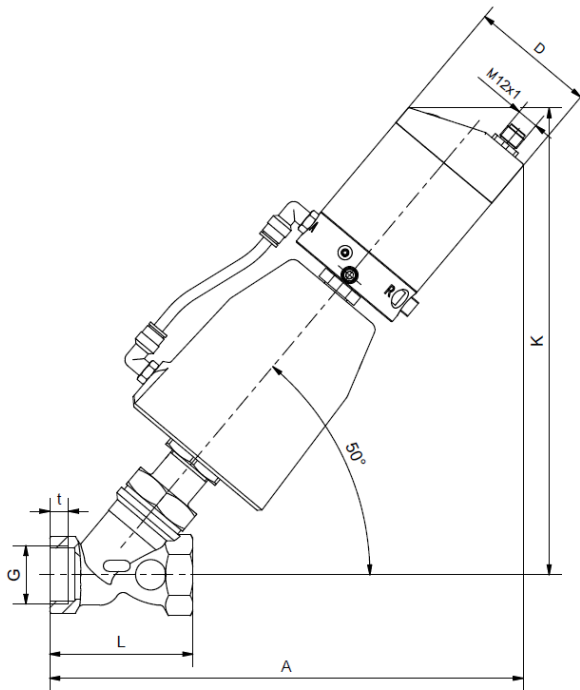

Actuator	7..5			7.58				7.63		
Type	.6323	.6324	.6325	.6325	.6326	.6327	.6328	.6326	.6327	.6328
G	1/2	3/4	1	1	1 1/4	1 1/2	2	1 1/4	1 1/2	2
A	227	229	232	264	273	280	290	315	320	332
D	70	70	70	70	70	70	70	70	70	70
K	219	220	222	260	265	271	280	315	322	330
L [RG5]	66	75	80	80	97	107	124	97	107	124
L [1.4408]	65	75	90	90	110	120	150	110	120	150
t [RG5]	13	14,5	10,5	10,5	12,5	14,5	16,5	12,5	14,5	16,5
t [1.4408]	12	13	15	15	17	19	21	17	19	21
kg	1,9	2,0	2,0	2,8	3,1	3,3	3,9	6,4	6,9	7,2

## ORDERING CODE

<b>. 6 3</b>	<b>2 3</b>	<b>/</b>	<b>0 8</b>	<b>0 4</b>	<b>/</b>	<b>7 5</b>	<b>1 5</b>	<b>-</b>	<b>4 R</b>
Type	Connection		Body material	Seal material		Actuator	Actuator size		Valve options
	23 G 1/2		08 St. steel 1.4408	04 PTFE		71 Standard	15 50 mm		4R Positioner
	24 G 3/4		11 Red brass RG5			75 chem. nickel pl.	55 50 mm		
	25 G 1						58 80 mm		
	26 G 1 1/4						63 125 mm		
	27 G 1 1/2								
	28 G 2								

## ORDERING CODE TYPE 22-4R

### GLOBE VALVES—FLANGED

[available Q2 2018]

. 2 2		/ 0 6		/ 0 5		/ 0 4		/ 7 5		6 3		- 4 R	
Type	Connection	Body material	Seal material	Actuator	Actuator size	Valve options							
	01 DN15	04 EN-GJL-250	04 PTFE	71 Standard	15 50 mm	4R Positioner							
	02 DN20	05 GP240GH		75 chem. nickel pl.	55 50 mm								
	03 DN25	08 St. steel 1.4408			58 80 mm								
	04 DN32				63 125 mm								
	05 DN40												
	06 DN50												
	07 DN65												
	08 DN80												
	09 DN100												

## ORDERING CODE TYPE 90-4R

### VALVES FOR CRYOGENIC MEDIA

[available Q2 2018]

A 9 0		/ 2 5		/ 0 8		/ 1 5		/ 7 0		5 8		- 4 R	
Type	Connection	Body material	Seal material	Actuator	Actuator size	Valve options							
A Body PN16	21 G 1/4	08 St. steel	15 PEEK	70 Standard	15 50 mm	4R Positioner							
B Body PN50	22 G 3/8	PN16: 1.4408		75 chem. nickel pl.	55 50 mm								
	23 G 1/2	PN50: 1.4581			58 80 mm								
	24 G 3/4				63 125 mm								
	25 G 1												
	26 G 1 1/4												
	27 G 1 1/2												
	28 G 2												

# INFORMATIONEN

- It is imperative to observe the installation and safety instructions in our operating and service manuals.
- Required ordering information: valve type, function NC/NO, pressure range, connection, nominal width, medium, flow rate, medium and ambient temperatures, connection voltage.
- Detailed production-specific drawings and other technical information will be made available when an order is placed.

## ELECTRICAL CONNECTION

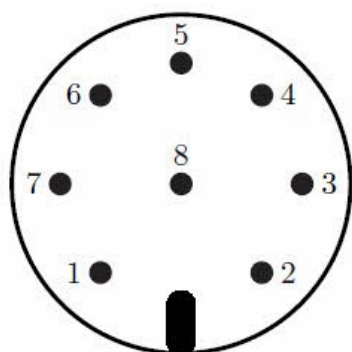

Pin 1 = white	Outlet 2	0-5 VDC - digital / constant
Pin 2 = brown	Supply voltage	24 VDC
Pin 3 = green	Ground	0 V
Pin 4 = yellow	Input signal	0-10 VDC
Pin 5 = gray	Output signal	0-10 VDC
Pin 6 = pink	Output 1	0-5 VDC - digital / constant
Pin 7 = blue	Input signal	4-20 mA
Pin 8 = red	Output signal	4-20 mA

**Note:**

The connected cable to the positioner must not be longer than 30 meters.

### Pease note

Each individual application decides which valve type is required, the main factor being the resistance of the materials to the operating medium. The correct selection of materials requires knowledge of the concentration, temperature and degree of contamination of the medium. Other criteria include the operating pressure and max. volumetric flow, since , in addition to high temperatures , high pressures and high flow rates must also be taken into account when selecting the materials.

**All materials used for our valves, be it housing, seals or magnets, will be carefully selected in view of the different application areas. Any information given is non-binding and serves for orientation only. No claims under warranty can be derived therefrom.**

- The GSR logo is a registered trademark of GSR Ventiltechnik GmbH & Co. KG.
- Note: All texts and images are the property of GSR Ventiltechnik GmbH & Co. KG and must not be replicated or modified, not even in part, without written approval.
- Original products may differ from the product images shown, due to different materials and the like.
- Subject to error and changes.

Stand: 02.18, MK-MG, Version 1.