

Beck.

The differential pressure transmitter 990 Display for air



Differential pressure transmitter 990 Display



General description

The transmitters of the 990 Display series are used to measure differential pressure, overpressure and vacuum. They offer one adjustable pressure range and two output signals.

Applications

Monitoring of gaseous, non-combustible and non-aggressive Media.

Possible usage areas are:

- Building automation and air conditioning systems
- Overpressure measurement in clean rooms and laboratories
- Measurement of constant pressure in VAV applications
- Dynamic filter and ventilator monitoring

Adjustable pressure range

To adapt the instrument to the application, the factory-set pressure range can be modified in the menu in a range from 100% to 50% of its full scale value.

Switchable pressure units

The instrument offers three different pressure units to show in the display, which can be selected in the menu. Factory setting is Pascal (kPa), which can be changed to mbar or inWC.

Switchable output signal

0 ÷ 10V or 4 ÷ 20mA, easy to switch in the menu. Further values on request.

Adjustable response time

The response time of the output signal can be configured using the menu in a range from 0.1 to 20 s.

Easy offset calibration

The output signal of the type 990M can be re-calibrated to zero in the menu when the instrument is in a pressure less state. The series 990A performs an automated zero offset compensation.

Volume flow measurement

The shape of the output signal can be changed in the menu from linear to square rooted to enable a volume flow measurement via a differential pressure reading.

Switching output

The differential pressure transmitter offers two adjustable potential-free switching outputs with a maximum switching capability of 50VAC/5A (S1) and 250VAC/5A (S2).

Measuring method

Piezoresistive pressure transducer.

Mounting position

Can be mounted in any position. The zero offset calibration eliminates any possible position error.

Technical data

Supply voltage	18 ... 30 VAC / VDC
Output signal	0 ... 10 V or 4 ... 20 mA
Maximum current draw 990M 990A	< 190 mA < 250 mA
Load for output 4 ... 20 mA 0 ... 10 V	20 ... 500 Ω ~ 1 k Ω (m10 mA)
Medium	Air and non-combustible and non-aggressive gases
Working temperature	0 ÷ 50°C
Storage temperature	-10 ... 70°C
Linearity (incl. hysteresis and repeatability)	m \pm 0.5% FS, min. \pm 1 Pa
Uncertainty (Total Error Band w/o long-term and temperature effects)	\pm 1% FS, min. \pm 1 Pa
Long-term stability 990M 990A	m \pm 1% FS n.r.
Humidity	0 ... 95% rel, non-condensing
Response time, switchable	0.1 . 20.0 s
Process connection P1 und P2	4 mm and 6 mm hose connection
Electrical connection	Screw terminals for wires and strands up to 1.5 mm ²
Mounting	Panel mounting in accordance with DIN IEC 61554
Display	Red 7 segment LED display, 4 digits
Housing dimensions LxWxH	143 x 96 x 48 mm
Weight	approx. 230 g
Protection class according to EN 60529	IP20
CE Conformance	EMC Directive RoHS Directive Low Voltage Directive

Accuracy specifications according to EN 60770 based on the pressure measurement at 23°C

Differential pressure transmitter 990 Display

Pressure ranges

Model	Pressure range			Overload capacity	Bursting pressure	Additional uncertainty with temperature [% FS/10K]	
	Unit 1	Unit 2	Unit 3			990M	990A
990A.303	0 ÷ 25 Pa	0.25 mbar	0.10 inWC	60 kPa	100 kPa	-	± 1.0
990A.313	0 ÷ 50 Pa	0.5 mbar	0.20 inWC	60 kPa	100 kPa	-	± 0.7
990x.323	0 ÷ 100 Pa	1.0 mbar	0.40 inWC	60 kPa	100 kPa	± 1.0	± 0.5
990x.333	0 ÷ 250 Pa	2.5 mbar	1.00 inWC	60 kPa	100 kPa	± 0.7	± 0.3
990x.343	0 ÷ 500 Pa	5.0 mbar	2.00 inWC	75 kPa	125 kPa	± 0.5	n.r.
990x.353	0 ÷ 1 kPa	10 mbar	4.00 inWC	75 kPa	125 kPa	± 0.3	n.r.
990x.363	0 ÷ 2.5 kPa	25 mbar	10.05 inWC	85 kPa	135 kPa	± 0.3	n.r.
990x.373	0 ÷ 5 kPa	50 mbar	20.10 inWC	135 kPa	275 kPa	± 0.3	n.r.
990x.383	0 ÷ 10 kPa	100 mbar	40.20 inWC	135 kPa	275 kPa	± 0.3	n.r.
990x.393	0 ÷ 25 kPa	250 mbar	100.50 inWC	135 kPa	275 kPa	± 0.3	n.r.
990x.3A3	0 ÷ 50 kPa	500 mbar	201.00 inWC	200 kPa	400 kPa	± 0.3	n.r.
990x.3B3	0 ÷ 100 kPa	1,000 mbar	402.00 inWC	200 kPa	400 kPa	± 0.3	n.r.
990x.3F3	0 ÷ 250 kPa	2,500 mbar	1,004.00 inWC	400 kPa	800 kPa	± 0.3	n.r.

Further pressure ranges on request.

Order matrix

Offset calibration	manual				990M.3	X	3	X	1	X
	automatic				990A.3	X	3	X	1	X
Pressure range	0 ... 25 Pa (0.25 mbar)		only available as 990A			0				
	0 ... 50 Pa (0.5 mbar)		only available as 990A			1				
	0 ... 100 Pa (1.0 mbar)					2				
	0 ... 250 Pa (2.5 mbar)					3				
	0 ... 500 Pa (5.0 mbar)					4				
	0 ... 1 kPa (10 mbar)					5				
	0 ... 2.5 kPa (25 mbar)					6				
	0 ... 5 kPa (50 mbar)					7				
	0 ... 10 kPa (100 mbar)					8				
	0 ... 25 kPa (250 mbar)					9				
	0 ... 50 kPa (500 mbar)					A				
	0 ... 100 kPa (1,000 mbar)					B				
	0 ... 250 kPa (2,500 mbar)					F				
Pressure unit	Pascal (kPa) ; mbar; inWC						3			
Output signal	0 ... 10 V or 4 ÷ 20 mA, with 2 switching outputs							1		
	4 ... 20 mA or 0 ÷ 10 V, with 2 switching outputs							3		
Display	Red LED display, 4 digits								1	
Electrical connection	via screw terminals for 24 VAC/VDC									4
	via wall power supply for 100 to 240 VAC, 50 to 60 Hz (supply)									5

Factory setting printed in old type.

Accessories

Climaset® consisting of 2 m PVC hose and 2 plastic pipes with 80 mm length	Article No. 6555
Climaset® consisting of 2 m Silicone hose and 2 plastic pipes	Article No. 6557
Climaset® consisting of 2 m PVC hose and 2 angled metal pipes	Article No. 6550
Climaset® consisting of 2 m Silicone hose and 2 angled metal pipes	Article No. 6556
Duct connecting pipe for Climaset® 6555	Article No. 6551
Angled metal pipe for Climaset® 6550	Article No. 6552
Rubber grommet for Climaset® 6550	Article No. 6553
Roll with 100 m PVC hose	Article No. 6424
Roll with 100 m Silicone hose	Article No. 6425
Wall power supply (Input 100 ... 240V / 50 ... 60Hz / max. 100mA; Output 24 VDC / 24W)	Article No. 6505
Front frame (as separate accessory)	Article No. 6506

Dimensional Drawings

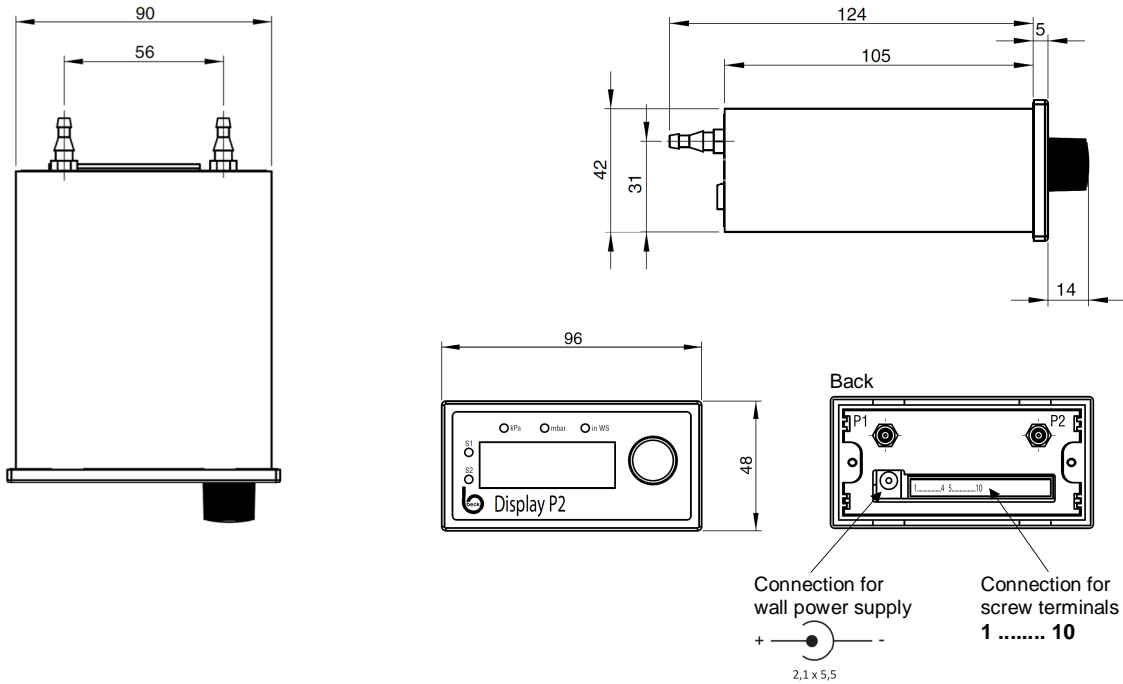

Connection plan

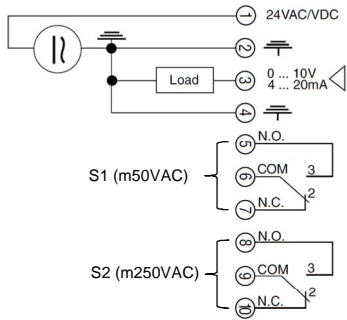

1	Supply voltage (18...30 VAC / VDC)
2	Ground (GND)
3	Output signal (0 ÷ 10 V / 4 ÷ 20 mA)
4	Ground (GND)
5	Switching output S1 (Operating contact N.O.)
6	Switching output S1 (Power supply line COM)
7	Switching output S1 (Break contact N.C.)
8	Switching output S2 (Operating contact N.O.)
9	Switching output S2 (Power supply line COM)
10	Switching output S2 (Break contact N.C.)

Analog output signal

Linear
0 . 10 V

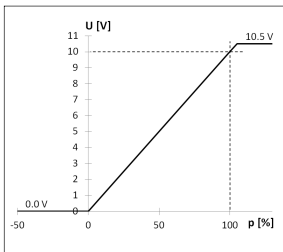

4 . 20 mA

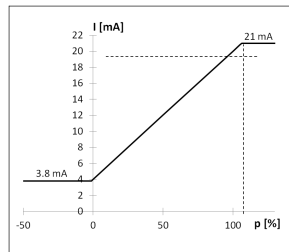

Square root
0 . 10 V

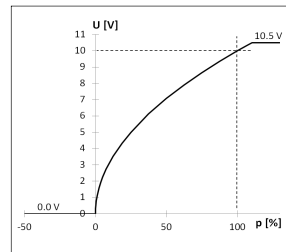

4 . 20 mA

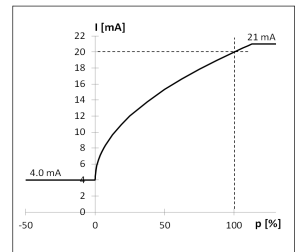

SCHIBUOLA LAURO

Via Nizza 65 10125 Torino - Italy
info@schibuola.com www.schibuola.com

