

# Hose Carrier HC

## PRODUCTS INFORMATIONS

### Hose Carrier HC 15

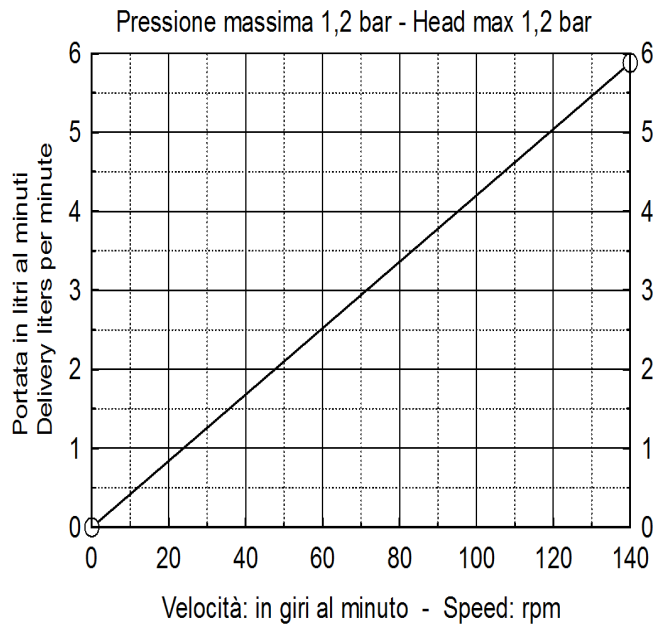

TECHNICAL DATA	
Delivery max	352 l/hour
Head max	1,2 bar
Vacuum	0,8 bar
Delivery per revolution	0,0425 liter
Barb hose	DN 20
Free passage	13 mm
Weight	
Power Kw	0,09 – 0,22
Tube available in different materials	TPK
	SIL
	VIT
Leakage sensor	Option
Cooling device	Option
Different connections	Option

#### VERSIONS AVAILABLE

- Variables with mechanical speed variator, from 1:5
- Variable electronic inverter integrated IP 56
- Trailers for slow hand towing in site
- Electrical control panels

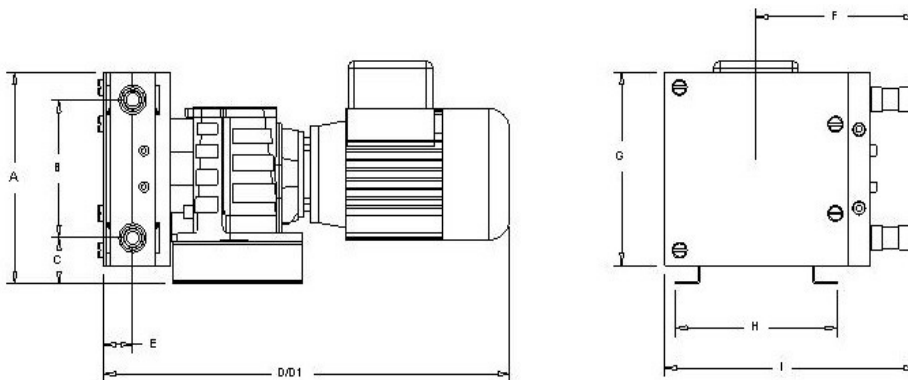

DIMENSIONS											
A	B	C	D	D1(VAR)	E	F	G	H	I	Out/In	Weight
175	114	38	355	455	25,5	140	160	142	220	DN20	

The dimensions are not binding and can vary without notice

# General data of the peristaltic pump Hose Carrier HC HC 15

## TECHNICAL FEATURES

Flow rate	peristaltic pump Hose Carrier HC HC 15
Pressure	up to 325 liters per hour
Aspiration	up to 1.2 bar
Free passage	up to 8 meters
Compact solid passage Mouths	diameter 13 mm
Applied power	diameter 3 mm
Voltage	hose connection DN 20 mm
Maximum dimensions Weight	0.09 - 0.22 kW Mono - Three phase
Tubular membrane material	H 175 x 455 x 220
	kg.
	TPK – SIL

## EXCLUSIVE ADVANTAGES of the Hose Carrier HC 15 pump:



- Economical purchase and operation.
- Ability to prime and run dry without damage.
- Online reversibility.
- High vacuum capacity up to 8 meters.
- Absence of valves or seals, rotors and stators that wear out.
- No contact between mechanical parts and pumped fluid.
- Pump body in aluminum or stainless steel.
- Rotor with two rollers mounted on bearings lubricated for life.
- Rollers with optional bearing protection.
- Double body versions.
- Direct flanged gearmotor or with dedicated autonomous support.
- Hose containment loops to extend its life.
- Forced grease or Lubex lubrication system.
- Pipe break control kit.

 **SCHIBUOLA LAURO**

Products for Plant Automation

[www.schibuola.com](http://www.schibuola.com) - [info@schibuola.com](mailto:info@schibuola.com)

tel. 011-6991507 - 011-6502223 cell. 3355367761

