

Hose Carrier

Tubular diaphragm
pumps for difficult
fluids



SCHIBUOLA LAURO

Products for Plant Automation

www.schibuola.com - info@schibuola.com

tel. 011-6991507 - 011-6502223 cell. 3355367761

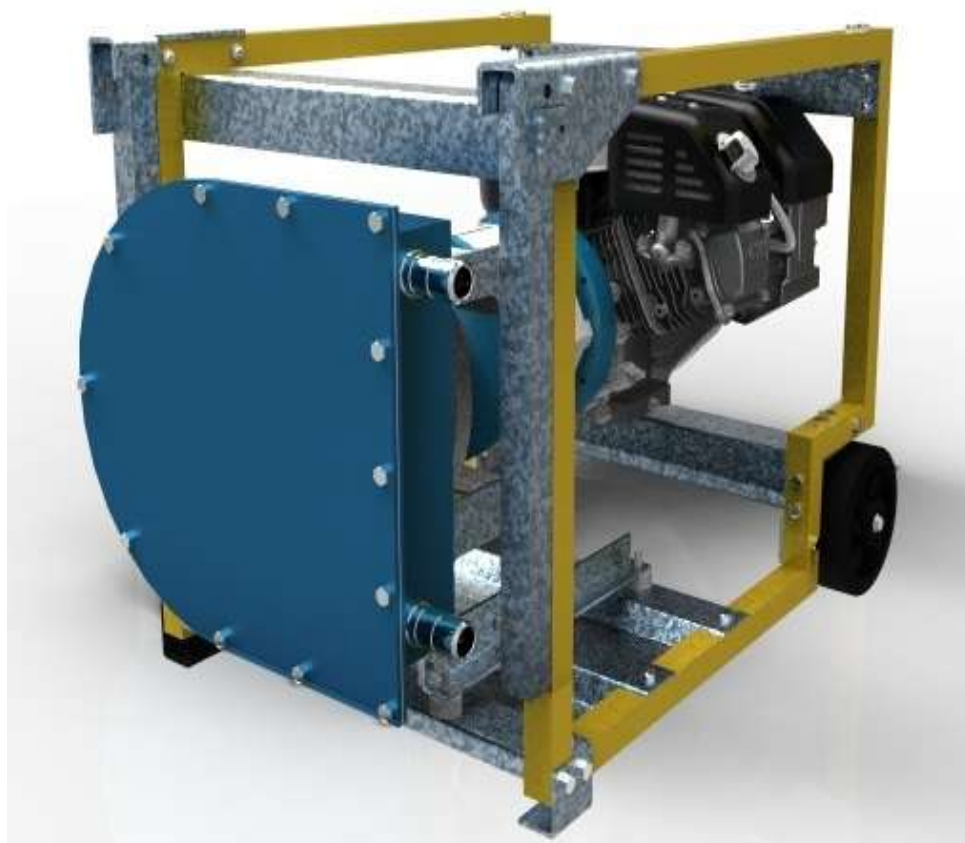

Motor pumps for general and emergency services



The efficient, versatile and resistant Hose Carrier pump to aggressive and erosive fluids.

Special cage in resistant and robust galvanized steel, total protection, available with perimeter panels.

Powerful and light engines, equipped with easy or electric starting on request.

Arrangement for battery housing in versions with electric start.

Solid rubber wheels for easy handling and positioning.

Transmission with disconnecter coupling to allow the motor to start without engaging the pump rotor.

Transmission with generously sized oil bearing support for intensive service.

Pump unit on rubber anti-vibration mounts to absorb vibrations during operation.

Foldable handles for easy transport, positioning and storage.

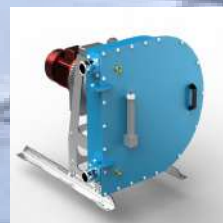
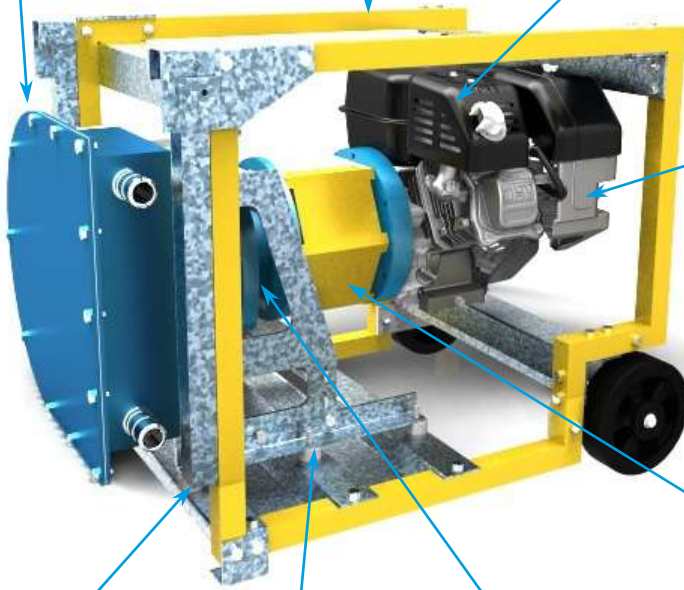

**HOSE CARRIER PUMPS MAXIMUM
EXPRESSION OF SIMPLICITY,
ESSENTIALITY, EFFICIENCY AND
PERFORMANCE**

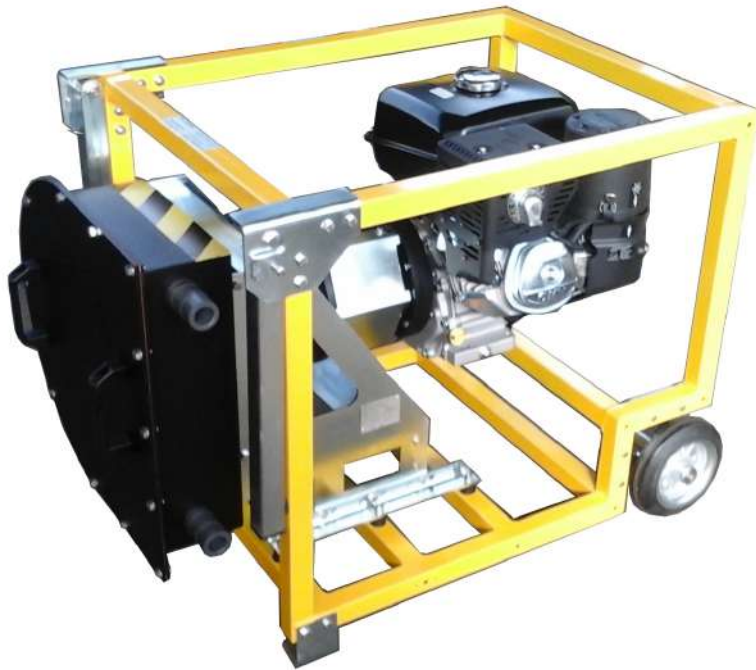

HOSE CARRIER MOTORPUMPSPER SERVIZI UNIVERSALI

Pumps for general services ed emergency.

Hose Carrier motor pumps are universal self-priming pumps suitable for basically any fluid, chemically aggressive, with solid suspensions, erosive, high viscosity with gas in solution.

Hose Carrier motor pumps guarantee:

- Dry priming up to a vacuum of 9.5 meters.
- Dry or discontinuous running capability.
- Suction in depth or at great distances.
- Delivery pressure up to 6 bar.
- Compatibility with almost all clean or waste industrial fluids.
- Maximum resistance to abrasion.
- Transport of compact and frangible solid substances.
- Only one wear part present, replaceable on site in a few minutes.
- Insignificant maintenance and use costs.
- Performance proportional to the motor rotation speed.
- Compatibility with very viscous fluids.

SECTORS OF USE

Ecological and environmental services.

Chemical industry.

Industrial sites and plants.

Naval, port and dock services.

Emergency services.

Logistics for the transport of chemical and various fluids, clean or wastewater.



Chemistry
Ecology
Emergency

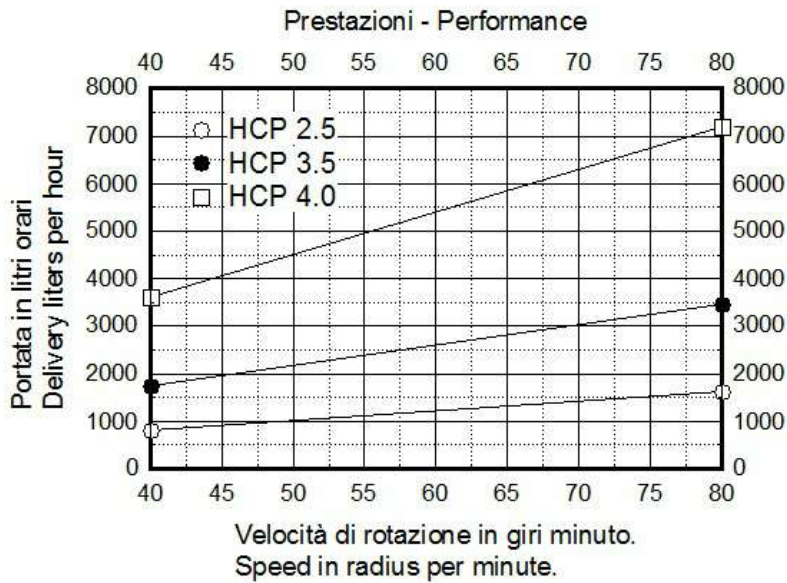

Ferroviario
Marina
Navale

Tipo	Motore Engine	Portata Delivery	Pressione Pressure	A	B	C	D	Bocche Inlet/outlet
HCP 2.5 MTP	Kohler SH265 6,5 Hp 3600 rpm	1,65 mc/h	4 bar	1144	785	580	598	DN 32
HCP 3.5 MTP	Kohler SH265 6,5 Hp 3600 rpm	3,6 mc/h	4 bar	1240	984	654	688	DN 40
HCP 4.0 MTP	Kohler CH395 9,5 Hp 3600 rpm	7,2 mc/h	4 bar	1496	996	780	765	DN 50

Membrane tubolari Hose material
NR
NBR
EPDM
HYPALON

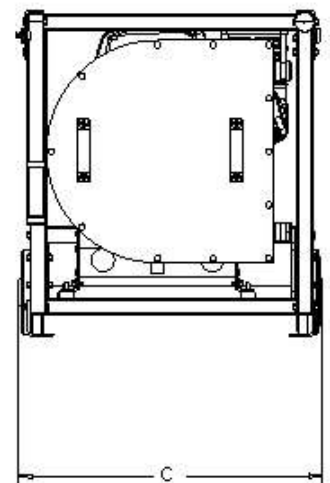
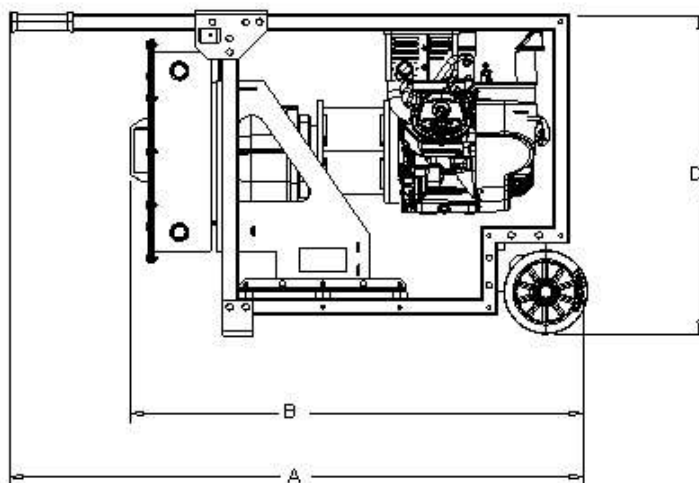

SCHIBUOLA LAURO

Products for Plant Automation

www.schibuola.com - info@schibuola.com

tel. 011-6991507 - 011-6502223 cell. 3355367761

