



VD10 PN16 - PN25

Pneumatic & Electric Globe Control Valve European std.

Manufactured under ISO 9001 quality assurance system, the OMC **VD10** is a Ductile Iron globe valve that can accommodate a wide range of different single stage trims.

VD10 series combines an advanced modular design and a wide range of actuators to satisfy the needs of industrial demands.

VD10 valves are designed to control a broad variety of fluids, like steam, water, and most gases. One of the main features of this series is the top guided construction that assure stable plug travel over entire stroke of the valve, minimizing vibration and wear.



14/68/EU Directive (PED)
14/34/EU (ATEX)



EAC Conformity
CU TR 010 / CU TR 032



Safety Integrity Level
IEC EN 61508 - TÜV



Fugitive emissions
ISO 15848-1

- ◆ DN15 ÷ DN200 PN 16/25
- ◆ DN250 PN16
- ◆ Top Guided construction to ensure plug stability
- ◆ Designed and engineered for robustness in demanding applications
Modular design
- ◆ CEI EN 60534-6-1 Clamp and Yoke Std.
- ◆ Std. self adjusting double packing spring loaded
- ◆ Shutoff capabilities : Class IV (std.) , V, VI

OPTIONS

Reduced area trim to provide wide capabilities for all sizes

Hardened trims to handle high pressure drop applications

Balanced trims to handle high pressure drop & shutoff

“Quick-Change” seat ring

Low noise & anticavitation design cage

Bellows seal to meet zero emissions (ZEB20)

Bonnet for low temperature and for high temperature

RTJ connections & special on request



REFERENCE STANDARDS

Quality system management certification	ISO 9001
Design std.	EN12516-2
Flange connection	EN 1092-2
Pressure Rating	PN16 / PN25
Face to face dimension	EN 558-1
Seat tightness Class	IEC 60534-4
Positioner mounting	CEI EN 60534-6-1
2014/68/EU (PED) Certification	Modulo B + C2
Mechanical resistance calculation method	UNI EN 12516-2
Hydrostatic pressure test	EN 12266-1
Pressure / Temperature relationship	EN 1092.2
2014/34/EU (ATEX) Conformity	II 2 G Ex h IIC T6...T1 Gb II 2 D Ex h IIIC T6...T1 Db
Non-electrical equipment for explosive atmospheres Basic method and requirements	EN ISO 80079-36
Safety Integrity Level (SIL)	IEC EN 61508
Safety Integrity Level (SIL) Approval	SIL 3 - (C-IS-722133629)
Fugitive emissions Certification	ISO 15848-1
EAC Conformity	CU TR 010 / CU TR 032
NACE	MR0175

STD VALVE BODY CHARACTERISTICS

Style	Top entry, single seated, globe valve
Sizes	from DN15 to DN250
Pressure rating	PN16 (from DN15 to DN250) / PN25 (from DN15 to DN200)
Design std.	EN12516-2
Flange connection	EN 1092-1- Raised Face - Phonography serrated 125-250 AARH
Face to face dimensions	EN 558-1

STD BODY & TRIM MATERIALS COMBINATION

VALVE BODY (1)	BONNET (9)	TRIM (2 and 3)	TIE ROAD	NUTS	BODY GASKET (11)
Ductile Iron EN-GJS-400-18 RT	ASTM A105	ASTM A182 F316	A193 B7	A194 H2	Graphite + Stainless steel

CONSTRUCTION EXAMPLES

1. Valve body
2. Seat ring
3. Plug
6. "Top Guide" stem
9. Bonnet
10. Stuffing box
11. Body gasket

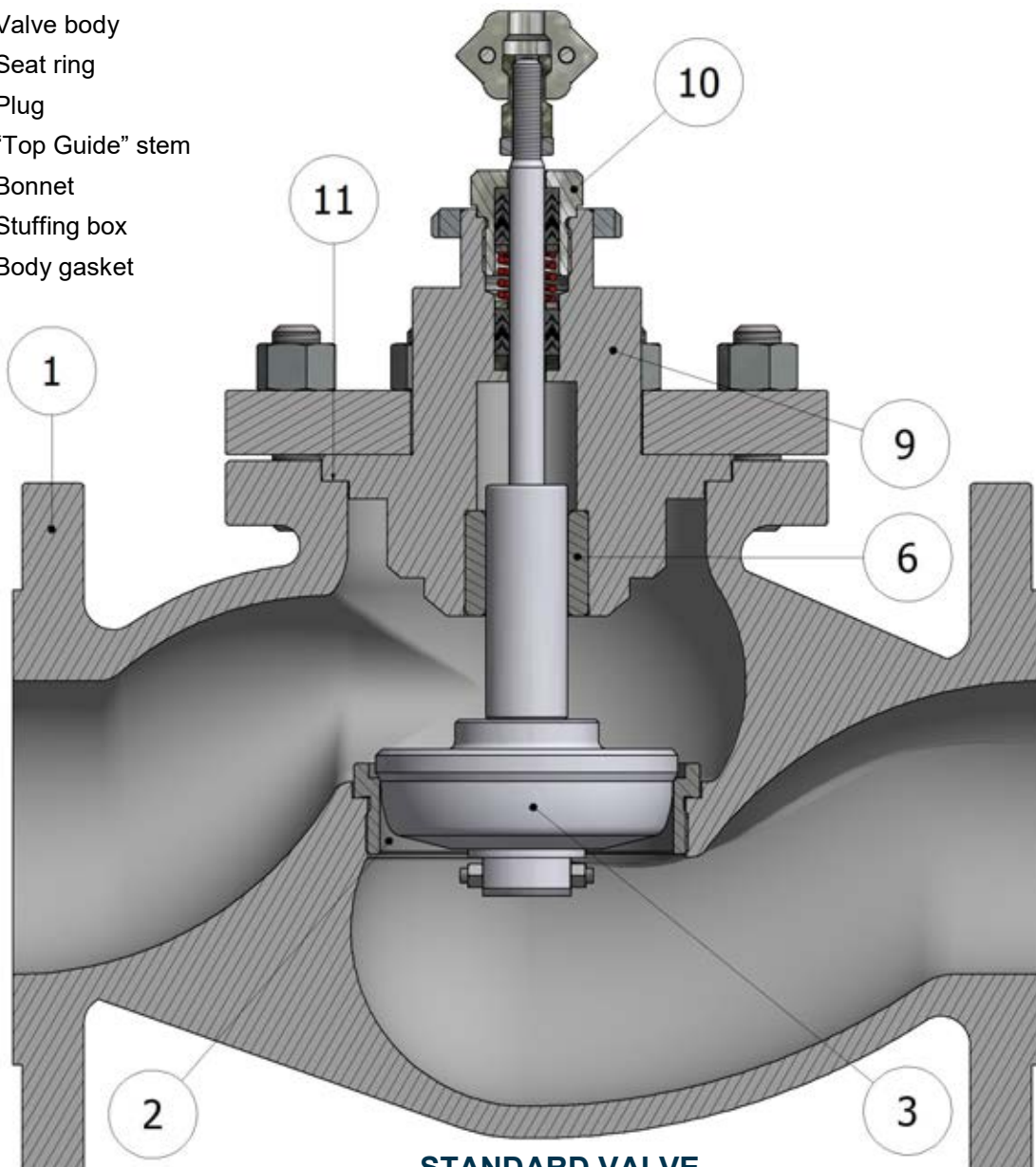

STANDARD VALVE

CONSTRUCTION EXAMPLES

1. Valve body
2. "Quick Change" seat
3. Plug
6. "Top Guide" stem
9. Bonnet
10. Stuffing box
11. Body gasket
13. Seat retainer
14. Seat gasket

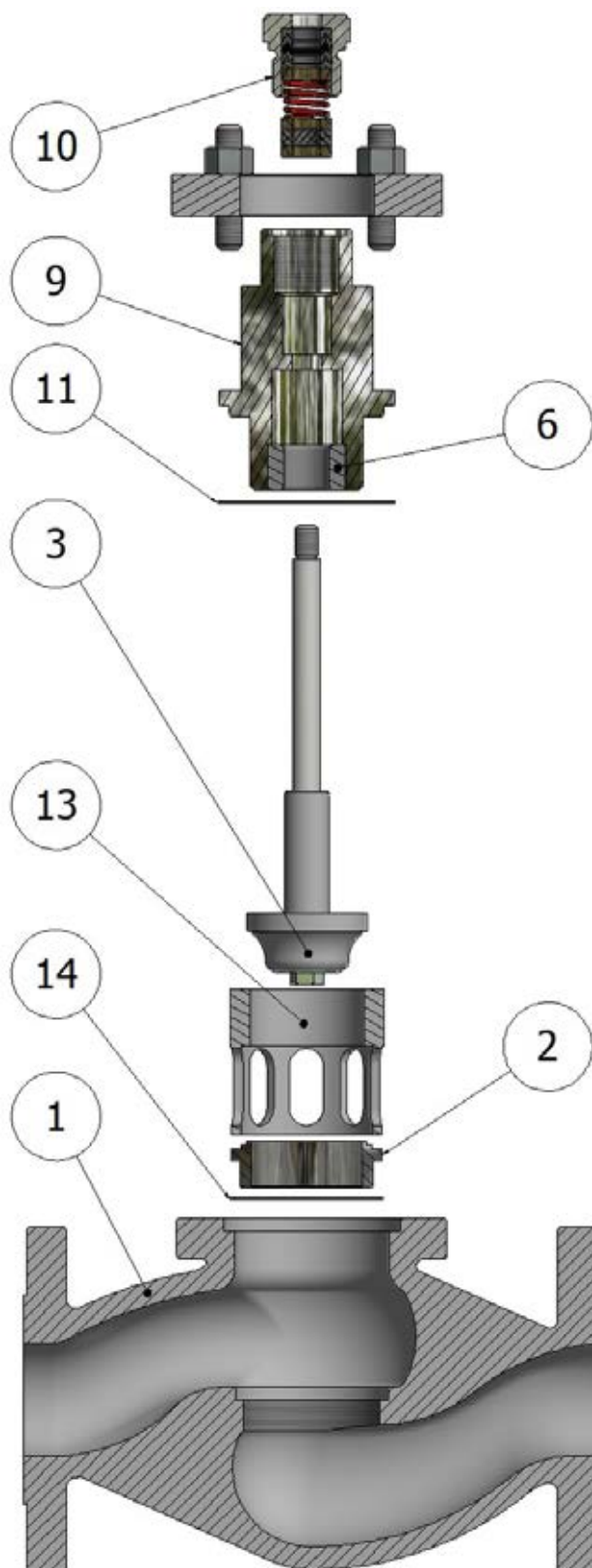

VALVE WITH QUICK CHANGE SEAT RING

Unlike the standard seat, the "Quick-Change" seat (2) is not screwed up but is blocked by the part (13). This guarantees a quick field replacement without the use of special equipment

CONSTRUCTION EXAMPLES

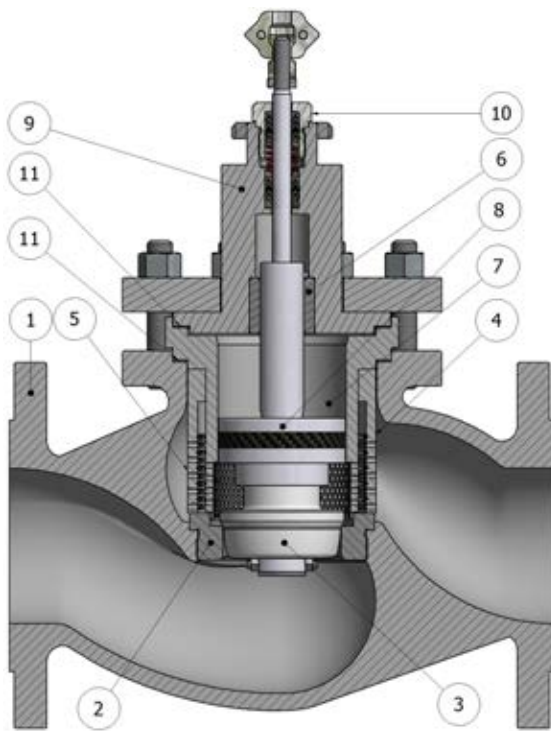

**BALANCED TRIM VALVE
WITH DOUBLE CAGE NOISE REDUCTION**

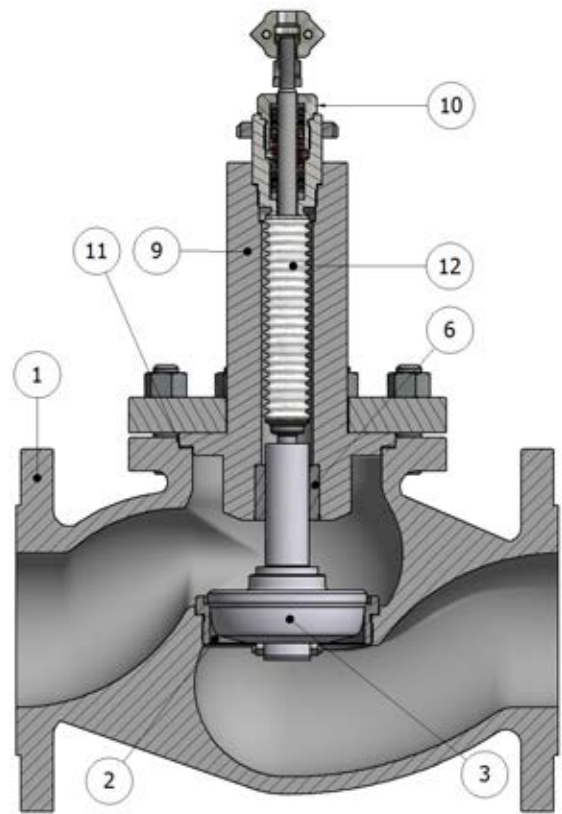

VALVE WITH BELLOWS

1. Valve body
2. Seat ring
3. Plug
4. 1st stage low dB Cage
5. 2nd stage low dB Cage
6. Top-guide stem
7. Balancing sleeve
8. Balancing piston
9. Bonnet
10. Stuffing box
11. Body Gasket
12. ZEB20 Bellows

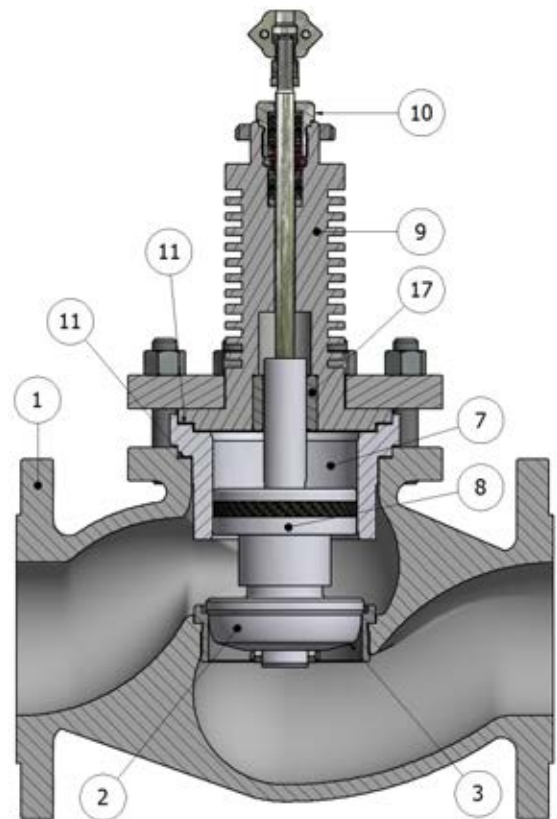

**BALANCED TRIM VALVE WITH
FINNED BONNET**

WORKING PRESSURE

TEMP.	EN-GJS-400-18 RT (5.3104)	
°C	PN16 (bar)	PN25 (bar)
-10 ÷ 120	16.0	25
150	15.5	24.3
200	14.7	23
250	13.9	21.8
300	12.8	20
350	11.2	17.5

WORKING PRESSURE

TEMP.	ASTM A105 / EN10273 1.0619 / EN1027	
°C	PN16 (bar)	PN25 (bar)
RT	16.0	25
100	14.8	23.2
150	14	22
200	13.3	20.8
250	12.1	19.0
300	11	17.2
350	10.2	16.0

STANDARD PROTECTIVE COATING

WORKING TEMPERATURE	VALVE BODY	BONNET
from -29° to 150°C	<ul style="list-style-type: none"> • Bicomponent anticorrosive acrylic primer at high resistance • Finish with bicomponent aliphatic acrylic enamel RAL 7021 opaque 	Electrolytic zinc coatings Fe/Zn 8 c1A UNI ISO 4520
from 150° to 250°C	<ul style="list-style-type: none"> • Siliconic primer • Finish with siliconic enamel RAL 9005 	Electrolytic zinc coatings Fe/Zn 8 c1A UNI ISO 4520
from 250° to 350°C	<ul style="list-style-type: none"> • Heat resistant siliconic primer • Finish with siliconic enamel RAL 9006 	

PNEUMATIC ACTUATOR STANDARD PROTECTIVE COATING

CASING AND YOKE

Polyester electrostatic epoxy powder coating - RAL 7032



RAL 7021

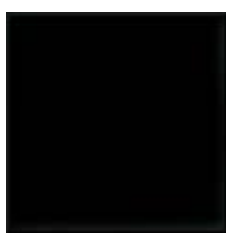

RAL 9005



RAL 9006



RAL 7032

Colors and shades shown in the figure are indicative

PROTECTIVE COATING ON REQUEST

Customer specification colors



Painting for sea environment

Painting in according to ISO 12944

Painting in according to NORSOK M-501

NACE - FROSIO painting

BONNET TYPES

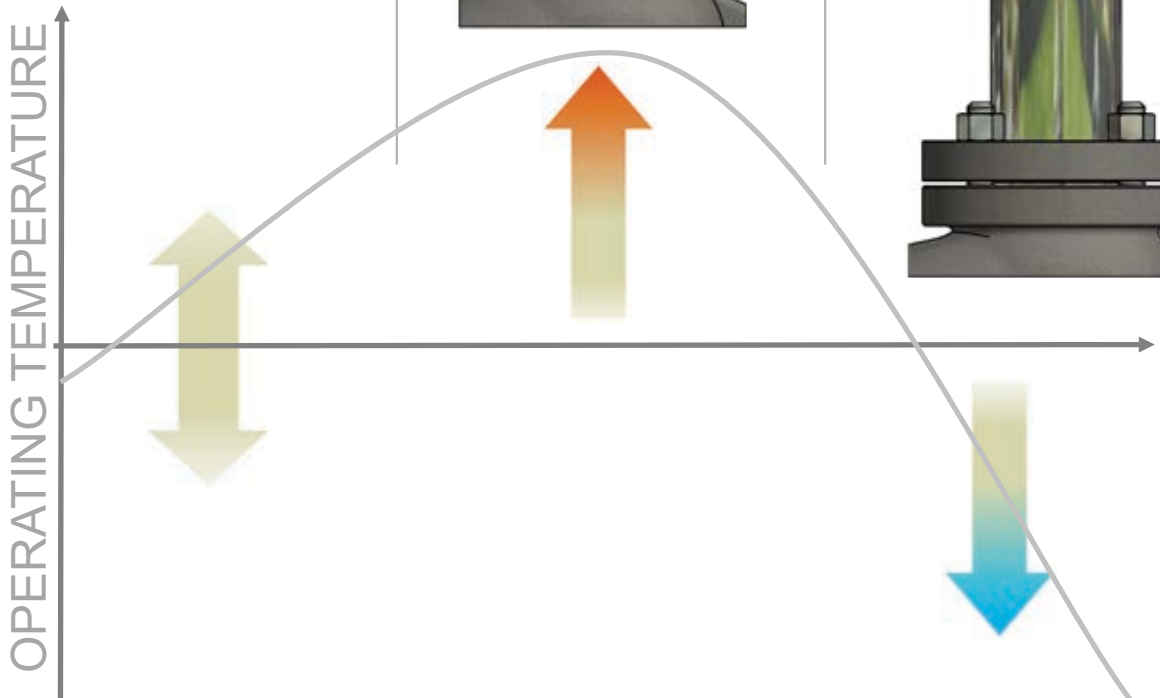
STANDARD	FINNED	EXTENDED
<p>The standard bonnet is cast or forged from the same or equivalent grade of material as the valve body. It is suitable for applications with temperatures between</p> <p>-5°C to +220°C</p>	<p>The finned bonnet is cast or forged from the same or equivalent grade of material as the valve body.</p> <p>Engineered for high temperature applications the fins dissipate heat and protect valve stem packing from extreme process temperatures up to +200°C</p> <p>-5°C ÷ 350°C</p>	<p>The extended bonnet is cast or forged from the same or equivalent grade of material as the valve body.</p> <p>To protect the stem packing the extended bonnet traps some process fluid. This provides a thermal buffer between the packing and the low temperature process fluid.</p> <p>Engineered for low temperatures, the extension length is manufactured to suit the applications where minimum temperature medium is below -5°C.</p> <p>-10°C ÷ 220°C</p>
		
		

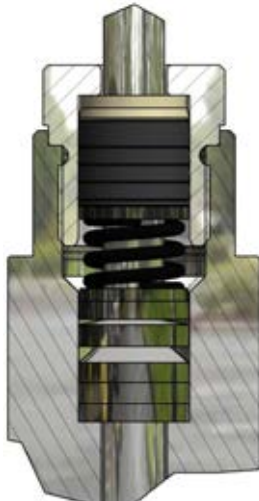

PACKING TYPES - VALVES FROM DN15 UP TO DN100

LP200	SP200	HP300	ECOPACK 1
<p>It consists of a series of energized V ring pack in Virgin PTFE and FKM, especially used with Oxygen and Cryogenic applications.</p> <p>Self-adjusting and maintenance free.</p>	<p>It consists of a series of energized V ring pack in PTFE base & FKM 75 Shore. Suitable for low & medium temperature application.</p> <p>Self-adjusting and maintenance free.</p>	<p>Directly in contact with the medium it consists of a series of energized V ring pack in Graphite and PTFE. Especially used for high temperature applications.</p> <p>Self-adjusting and maintenance free.</p>	<p>Made of a series of energized V ring pack in Graphite/PTFE. ISO 15848-1 Certified for Low emission fugitive test.</p> <p>Self-adjusting and maintenance free.</p>
			

PACKING / BONNET TEMPERATURE CORRELATION

	LP200	SP200	HP300	ECOPACK 1
EXTENDED BONNET	-10 ÷ 180°C	-10 ÷ 220°C	///	-10 ÷ 220°C
STANDARD BONNET	-5 ÷ 180°C	-5 ÷ 220°C	///	-5 ÷ 220°C
FINNED BONNET	///	-5÷260°C	-5 ÷ 350°C	-5 ÷ 350°C
EXTENDED BONNET FOR BELLOWS	-10 ÷ 180°C	-10÷260°C	-5 ÷ 350°C	-5 ÷ 350°C

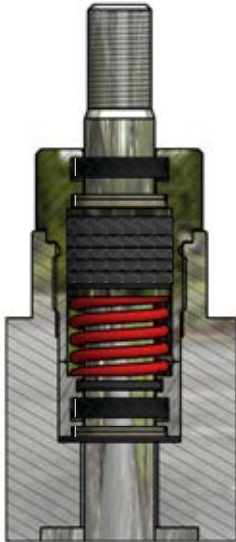
PACKING TYPES - VALVES FROM DN125 UP TO DN250

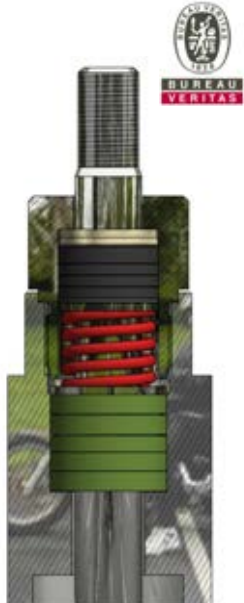
	LP400	SP400	HP600	ECOPACK 2
	<p>It consists of a series of energized V ring pack in Virgin PTFE and FKM, especially used with Oxygen and Cryogenic applications.</p> <p>Self-adjusting and maintenance free.</p>	<p>It consists of a series of energized V ring pack in PTFE base & FKM 75 Shore. Suitable for low & medium temperature application.</p> <p>Self-adjusting and maintenance free.</p>	<p>Directly in contact with the medium it consists of a series of energized V ring pack in Graphite and PTFE. Especially used for high temperature applications.</p> <p>Self-adjusting and maintenance free.</p>	<p>Made of a series of energized V ring pack in Graphite/PTFE. ISO 15848-1 Certified for Low emission fugitive test.</p> <p>Self-adjusting and maintenance free.</p>
				

PACKING / BONNET TEMPERATURE CORRELATION

	LP400	SP400	HP600	ECOPACK 2
EXTENDED BONNET	-10 ÷ 180°C	-10 ÷ 220°C	///	-10 ÷ 220°C
STANDARD BONNET	-5 ÷ 180°C	-5 ÷ 220°C	///	-5 ÷ 220°C
FINNED BONNET	///	-5÷260°C	-5 ÷ 350°C	-5 ÷ 350°C
EXTENDED BONNET FOR BELLOWS	-10 ÷ 180°C	-10÷260°C	-5 ÷ 350°C	-5 ÷ 350°C

ZEB20 BELLOWS FOR DANGEROUS FLUID

ZEB20 is specifically designed for industrial applications where the possible leakage of process fluid from the packing can cause environmental or personal damage and in extreme cases be hazardous to health.

The ZEB20 is manufactured by welding a bellows to the plug stem and valve bonnet. This removes potential leakage paths, while allowing full movement of the stem. The design provides total isolation of the fluid from the outside environment.

The ZEB20 also includes secondary stem seals as a safety function. These only operate in the unlikely event that a bellows ruptures. The secondary seals will provide reduced risk.

The standard of the bellows material is AISI 316L but, it is also available in other materials, including Inconel, Monel, Hastelloy, etc...

For safety critical applications the ZEB20 can be fitted with a test connection to allow the addition of feedback devices that monitor the integrity of the bellows

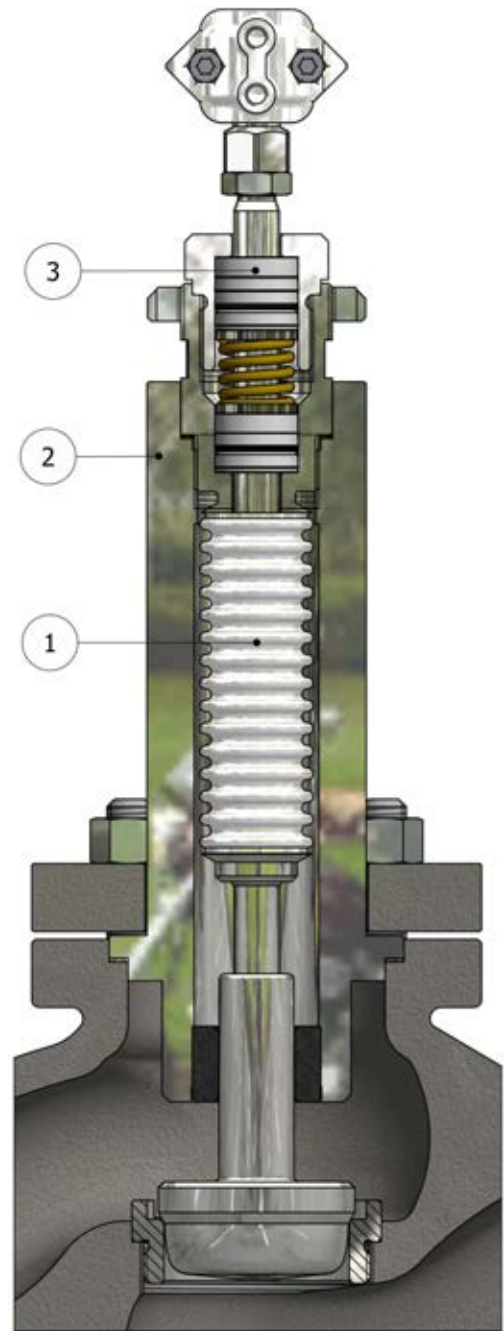

Fugitive emissions

ISO 15848-1

ZEB20 MATERIALS COMBINATION

POS.	DESCRIPTION	STD MATERIALS	ON REQUEST	TEMPERATURE
1	Bellows	AISI 316L	Inconel, Monel, Hastelloy, or other materials	-10°C ÷ 350°C
2	Bonnet	ASTM A105	Other materials	-10°C ÷ 350°C
3	Packing	See packing type chapter		

CONTROL CHARACTERISTICS

QUICK OPENING	LINEAR	EQUAL PERCENTAGE
<p>A valve with quick opening flow characteristic provides a maximum change in flow rate at low travels and small changes when the valve plug is near maximum. Control valves with quick opening flow characteristics are often used for on/off applications where significant flow rate must be established quickly as the valve begins to open. Consequently they are often used in relief valve applications. Quick opening valves can also be selected for many of the same applications for which linear flow characteristics are recommended.</p>	<p>A valve with linear characteristic provide a flow rate directly proportional to travel. Linear characteristics are commonly specified for liquid-level and flow-control applications.</p>	<p>In equal percentage flow characteristic, equal increments of valve travel produce equal percentage changes in the existing flow. A valve with an inherent equal percentage flow characteristic provides precise throttling control through the lower portion of the travel range and rapidly increasing capacity as the valve plug nears the wide open position. Valves with equal percentage flow characteristics are used on pressure control applications, on applications where a large percentage of the pressure drop is normally absorbed by the system itself with only a relatively small percentage available at the control valve, and on applications where highly varying pressure drop</p>

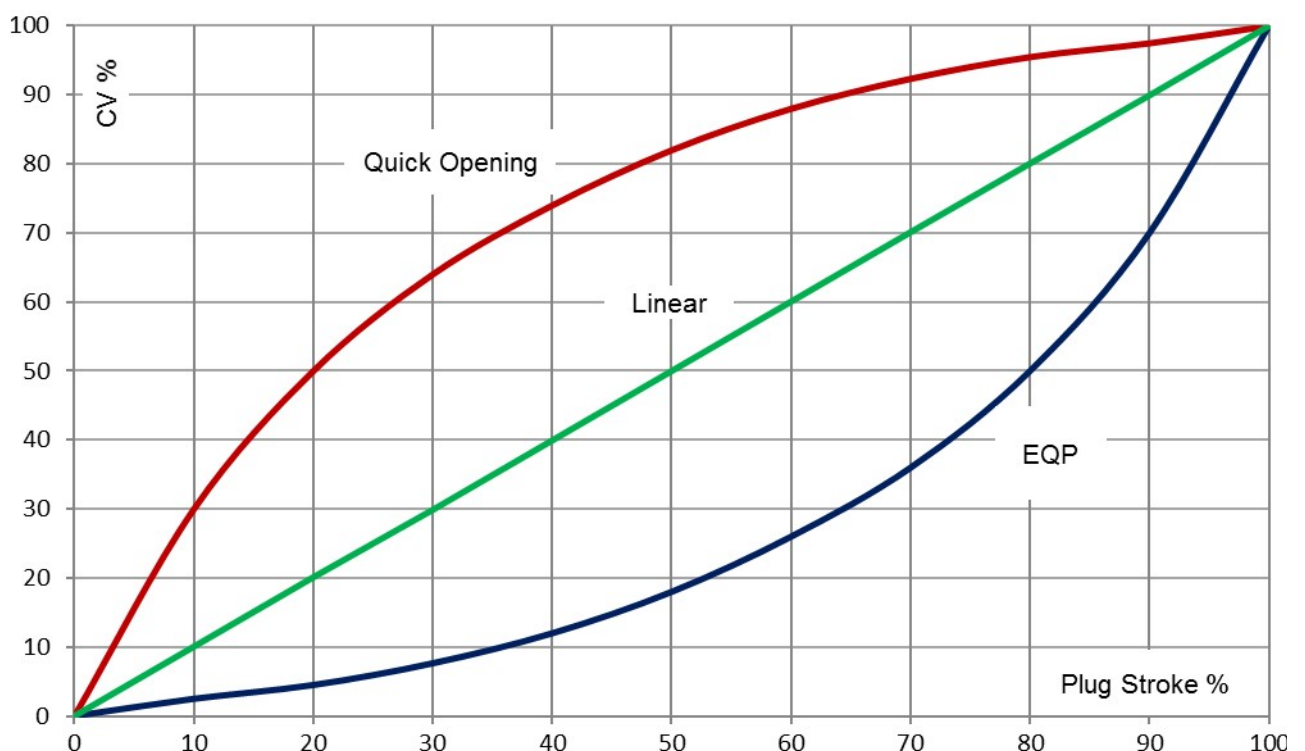

TRIMS CHARACTERISTICS

	STANDARD	ON REQUEST
CONTROL CHARACTERISTICS	Equal Percentage (EQP)	Quick opening (ON-OFF) Linear (PL)
PORT	Full port	Reduced port Microflow port
SEAL	Metal seat tightness Class IV	Stellite faced seat/plug Class IV Saline nitriding (QPQ) seat/plug Class IV Stellite faced seat/plug Class V - Lapped Only with quick-change seat Lapped seat/plug Class V Only with quick-change seat PTFE soft seal <300°F (150°C) - Class VI PTFE-GR soft seal <375°F (190°C) - Class VI PEEK Soft seal <536°F (280°C) - Class VI

LINEAR SPLINE PLUG	QUICK OPENING PLUG	EQP PLUG METAL TIGHTNESS	EQP PLUG SOFT TIGHTNESS
			

BALANCED PLUG CONSTRUCTION

In applications where there is a high flow rate and a high pressure drop valve actuators can struggle to provide tight shut off against the force of the upstream pressure on the plug. In these applications the balanced plug option redirects some of the upstream pressure to balance the influence of the pressure drop across the plug. This results in a more efficient actuator thrust for a particular size of actuator. This ensures the tightness class of the valve.

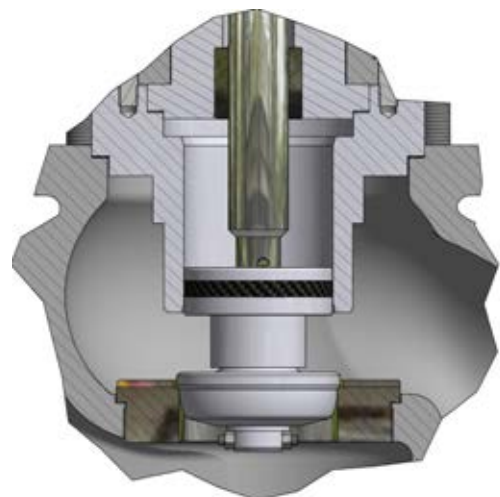

Balanced trim

CAVITATION, FLASHING EFFECT NOISE LEVEL

The globe valve allows the regulation of a parameter which can be the pressure or flow going to modify the flow of pressurized fluid in the system. The principle used is that of the Bernoulli law or the continuity of the fluids. In a globe valve, if I decrease the passage section, the speed increases while the pressure decreases. If this pressure falls below the vapor pressure of the bubbles could be created that could produce two flow disturbance phenomena:

Cavitation effect **Flashing effect**

Cavitation consists of rapid vaporization and condensation within a liquid. When local pressure falls to vapor pressure (approximately 0.25 psi / 0.018 bar absolute for cold water), vapor bubbles are formed and when these bubbles travel to an area of higher pressure, the bubbles collapse with phenomenal force and great localized stress. It is the violent collapse of these vapor bubbles near valve components or downstream piping surfaces, which cause cavitation damage and subsequent performance degradation. Typically, the reason for low pressure is that the pressure drop across a control valve has created very high velocity in the seat area and corresponding low pressure because potential (pressure) energy is reduced to compensate for the increase in kinetic energy. The principle can be applied to various types of fluid flow and simply states that when there is an increase in the velocity of fluids then it must be accompanied by a decrease in the fluid's pressure, the total energy associated with the flow must remain constant.

The **Flashing** effect is similar to cavitation, except that bubbles explode downstream of the valve.

In control valves, the pressure drop typically occurs at or near the seat area or just downstream. The shock waves and pressure fluctuations resulting from these high velocity bubble collapses can also cause noise, vibrations, accelerated corrosion, as well as limited valve flow. Typically the cavitation is formed in the valve throttling area, the pressure fluctuations radiate into the downstream pipe as noise

The KA10 Series can be equipped with anticavitation and or low noise trims to reduce the possibility of cavitation and noise.



Anticavitation Cage



Low dB Trim single stage

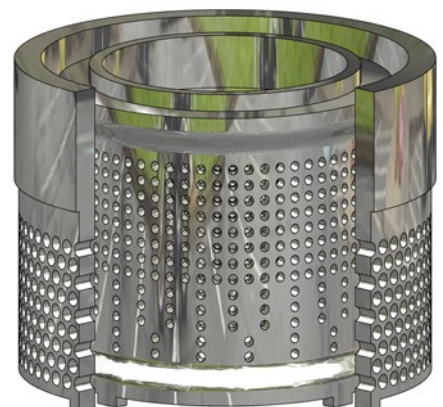

Low dB Trim double stage

EQUAL PERCENTAGE PLUG FLOW RATE COEFFICIENTS SEAT BORE DIAMETER AND STROKE

CV	Kv	Seat bore mm	Plug stroke mm	Valve size													
				15	20	25	32	40	50	65	80	100	125	150	200	250	
0.08	0.07	3	20	□	□	□	□	□	□	—	—	—	—	—	—	—	
0.20	0,17	4		□	□	□	□	□	□	—	—	—	—	—	—	—	—
0.60	0,51	5		□	□	□	□	□	□	—	—	—	—	—	—	—	—
1.00	0,85	7		□	□	□	□	□	□	—	—	—	—	—	—	—	—
1.3	1,11	8		□	□	□	□	□	□	—	—	—	—	—	—	—	—
1.8	1,54	9		□	□	□	□	□	□	—	—	—	—	—	—	—	—
2	1,7	10		□	□	□	□	□	□	—	—	—	—	—	—	—	—
2.5	2.15	10		□	□	□	□	□	□	—	—	—	—	—	—	—	—
3	2,58	10		□	□	□	□	□	□	—	—	—	—	—	—	—	—
3.5	3	10		□	□	□	□	□	□	□	—	—	—	—	—	—	—
5.5	4.7	20		■	□	□	□	□	□	□	□	—	—	—	—	—	—
8	6,8	20		—	■	□	□	□	□	□	□	—	—	—	—	—	—
13	11	25		—	—	■	□	□	□	□	□	—	—	—	—	—	—
19	16	30		—	—	—	■	□	□	□	□	□	—	—	—	—	—
29	25	38		—	—	—	—	■	□	□	□	□	□	—	—	—	—
50	43	49		—	—	—	—	—	■	□	□	□	□	□	—	—	—
75	64	64		—	—	—	—	—	—	■	□	□	□	□	□	—	—
112	96	76	—	—	—	—	—	—	—	■	□	□	□	□	□	—	
173	148	100	—	—	—	—	—	—	—	—	■	□	□	□	□	□	
190	162	100	35	—	—	—	—	—	—	—	—	□	□	□	□	□	
270	231	126	50	—	—	—	—	—	—	—	—	—	■	□	□	□	
410	351	151		—	—	—	—	—	—	—	—	—	—	—	■	□	□
720	615	201	60	—	—	—	—	—	—	—	—	—	—	—	■	□	
990	856	250	75	—	—	—	—	—	—	—	—	—	—	—	—	■	

— not available ■ standard □ on request

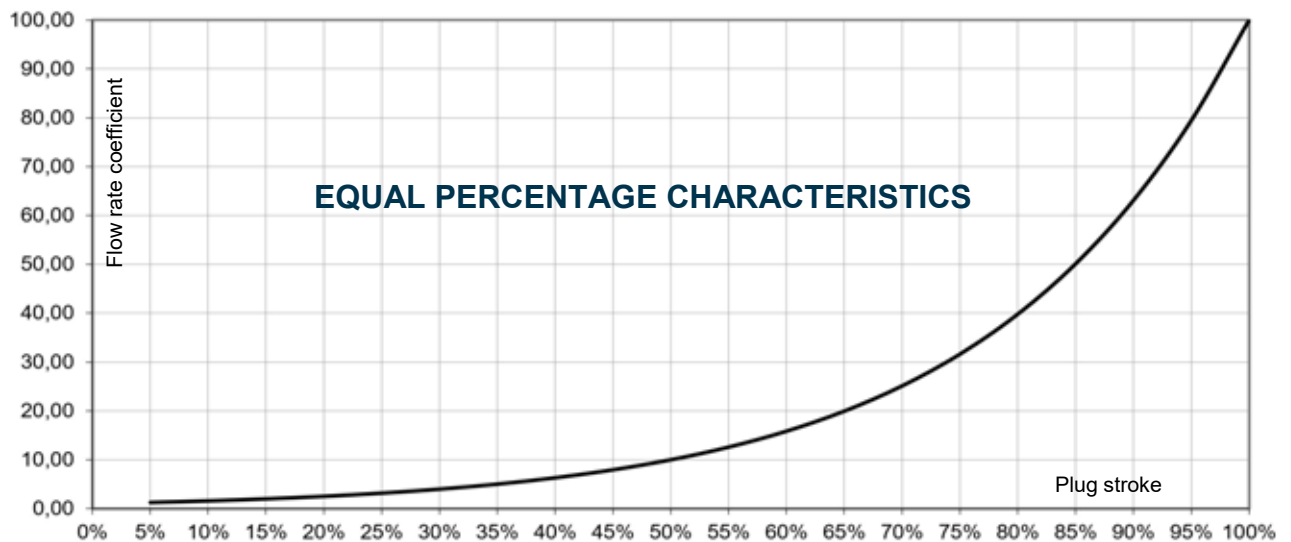

LINEAR AND QUICK OPENING PLUG FLOW RATE COEFFICIENTS SEAT BORE DIAMETER AND STROKE

CV	Kv	Seat bore mm	Plug stroke mm	Valve size													
				15	20	25	32	40	50	65	80	100	125	150	200	250	
0.03	0,02	3	20	□	□	□	□	□	□	—	—	—	—	—	—	—	
0.05	0,04	3		□	□	□	□	□	□	—	—	—	—	—	—	—	—
0.08	0,07	3		□	□	□	□	□	□	—	—	—	—	—	—	—	—
0.20	0,17	4		□	□	□	□	□	□	—	—	—	—	—	—	—	—
0.60	0,51	5		□	□	□	□	□	□	—	—	—	—	—	—	—	—
0.75	0,65	6		□	□	□	□	□	□	—	—	—	—	—	—	—	—
1.00	0,85	7		□	□	□	□	□	□	—	—	—	—	—	—	—	—
1.3	1,11	8		□	□	□	□	□	□	—	—	—	—	—	—	—	—
1.8	1,54	9		□	□	□	□	□	□	—	—	—	—	—	—	—	—
2	1,7	10		□	□	□	□	□	□	—	—	—	—	—	—	—	—
2.5	2.15	10		□	□	□	□	□	□	—	—	—	—	—	—	—	—
3	2,58	10		□	□	□	□	□	□	—	—	—	—	—	—	—	—
3.5	3	10		□	□	□	□	□	□	□	—	—	—	—	—	—	—
6	5,1	20		■	□	□	□	□	□	□	□	—	—	—	—	—	—
8	6,8	20		—	■	□	□	□	□	□	□	—	—	—	—	—	—
13	11	25		—	—	■	□	□	□	□	□	—	—	—	—	—	—
19	16	30		—	—	—	■	□	□	□	□	□	□	—	—	—	—
29	25	38		—	—	—	—	■	□	□	□	□	□	□	□	□	□
50	43	49	—	—	—	—	—	■	□	□	□	□	□	□	□	□	
75	64	64	30	—	—	—	—	—	—	■	□	□	□	□	□	□	
112	96	76		—	—	—	—	—	—	—	■	□	□	□	□	□	
173 ^a	148	100		—	—	—	—	—	—	—	—	■	□	□	□	□	
190	162	100	35 ^b	—	—	—	—	—	—	—	—	□	□	□	□	□	
280	239	126	50	—	—	—	—	—	—	—	—	—	■	□	□	□	
435	372	151		—	—	—	—	—	—	—	—	—	—	—	■	□	□
720	615	201	60	—	—	—	—	—	—	—	—	—	—	—	■	□	
990	856	250	75	—	—	—	—	—	—	—	—	—	—	—	—	■	

— not available ■ standard □ on request

a) not available for quick opening characteristic

b) 30mm for quick opening characteristic

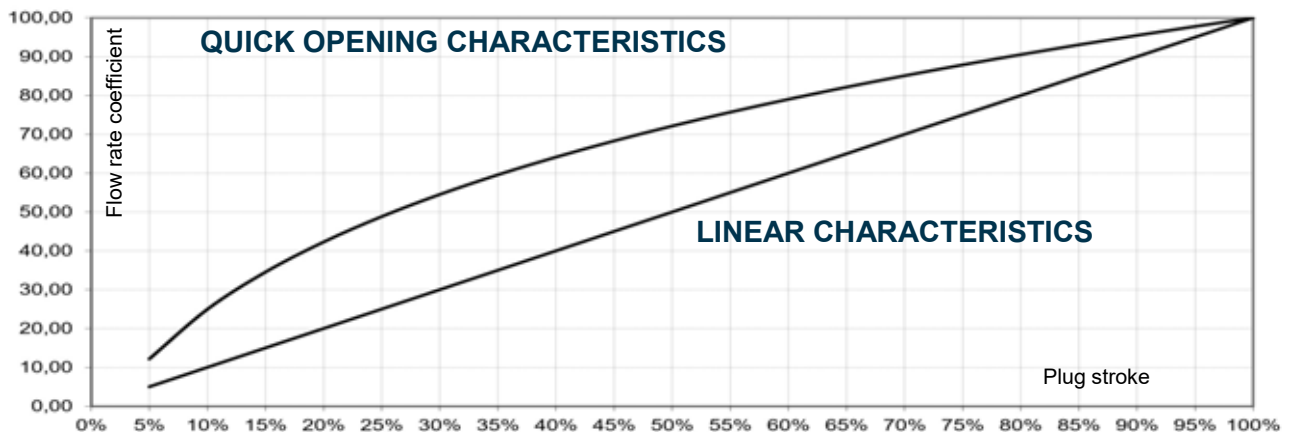

AP SERIES PNEUMATIC ACTUATORS - SPECIFICATIONS

AP series pneumatic actuators are multi diaphragm actuators. They are Available with four (4) different sizes of internal diaphragms. They are extremely compact and they can guarantee a perfect linearity to satisfy the control needs of the valves at different working pressures. They are equipped with an industry standard yoke (CEI EN 60534-6-1), which ensures accessories can be fitted quickly and easily. A full range E/P positioners, solenoid valves, limit switch boxes and feedback devices are available as option. As you standard a mechanical travel indicator and index scale are included as standard on all actuators.

TECHNICAL DATA

TYPE	Diaphragm type - multispring
CONTROL SIGNAL	Direct Action (Air to close - valve normally open) 3÷15psi ; 6÷18psi; 6÷30psi; 15÷60psi Reverse (Air to open - valve normally closed) 3÷15psi ; 6÷18psi; 6÷30psi; 15÷60psi
MAX AIR SUPPLY PRESSURE	50 psi (3,5bar) for signals 3÷15psi ; 6÷18psi; 6÷30psi; 87 psi (6 bar) for signal 15÷60 psi
PNEUMETIC CONNECTION	1/4" NPF-F

MATERIALI

	STANDARD	ON REQUEST
YOKE	ASTM A216 WCB (T.amb \geq -29°C)	Stainless steel ASTM A351 CF8 (T.amb \geq -268°C)
HOUSING	Steel 1.0332 / 1.0335 (T.amb \geq -50°C) ASTM A216 WCB (*) (T.amb \geq -29°C)	Stainless steel AISI 304 (T.amb \geq -268°C) Stainless steel ASTM A351 CF8 (*) (T.amb \geq -268°C)
BOLTS AND NUTS	A193 B7 - A194 2H (T.amb \geq -30°C)	A193 8M - A194 8M (T.amb \geq -268°C)
DIAPHRAGM	NBR (T.amb -35÷90°C)	EPDM (T.amb -50÷120°C) PVMQ (T.amb -60÷90°C)
SPLINDE	ASTM 182 F304	//
VALVE CLAMP CONNECTION	ASTM A 351 CF8	//
SPRING	EN 10270-1 SH painted (T.amb \geq -30°C)	EN 10270-3 1.4310 (AISI 301) EN 10270-3 1.4401(AISI 316) (T.amb \geq -268°C)
INTERNAL PARTS	Zinc plated Steel 1.0332 / 1.0335 (T.amb \geq -50°C)	Stainless steel AISI 304

(*) Actuators Series AP6.. only

1. Casing
2. Spring
3. Diaphragm
4. Splinde
5. Integral yoke
6. Valve clamp connection
7. Stroke indicator
8. Diaphragm plate

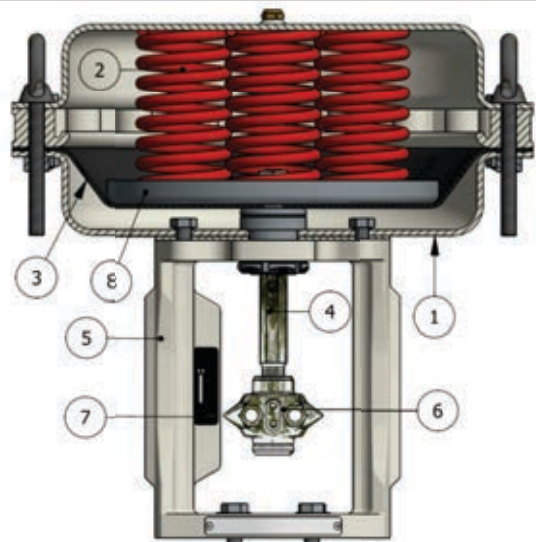

MAXIMUM ADMISSIBLE PRESSURE DROPS IN bar (FLUID OPEN) FOR UNBALANCED CONSTRUCTION

ACTUATOR	THRUST kN	Signal (psi)	CV 5.5 CV 6.0		CV 8		CV 13		CV 19		CV 29		CV 50		CV 75		CV 112		CV 173		CV 190		CV 270 CV 280		CV 410 CV 435		CV 720			
			cl IV	cl VI	cl IV	cl VI	cl IV	cl VI	cl IV	cl VI	cl IV	cl VI	cl IV	cl VI	cl IV	cl VI	cl IV	cl VI	cl IV	cl VI	cl IV	cl VI	cl IV	cl VI	cl IV	cl VI	cl IV	cl VI	cl IV	cl VI
			AP23	0.3	3+15	14	18	14	18	9	12	5	8	3	4	2	3													
0.4	6+18	16		22	16	22	11	17	7	10	4	5	3	4																
0.6	6+30	22		28	22	28	16	25	10	15	6	8	4	6																
1.5	15+60	45		60	45	60	35	56	27	33	15	17	8	12																
AP28	0.6	3+15	27	30	27	30	17	26	8	15	6	9	4	6																
	1.0	6+18	38	40	38	40	21	30	13	19	10	12	5	8																
	1.2	6+30	50	55	50	55	26	47	23	26	12	16	7	12																
	2.4	15+60	80	90	80	90	48	75	40	56	25	38	17	23																
AP34 / AP35	1.2	3+15	60	65	60	65	50	55	20	23	12	18	10	16	4	4	2	3	1	1										
	1.5	6+18	80	85	80	85	60	65	30	35	15	18	12	15	6	7	4	5	2	3										
	1.9	6+30	99	99	99	99	80	85	40	45	20	25	14	16	7	8	5	6	3	3										
	3.5	15+60							62	65	36	45	25	29	11	13	8	11	6	6										
AP43 / AP44	2.8	3+15									35	40	24	26	7	8	6	6	4	4										
	3.3	6+18									40	45	26	28	9	10	8	8	5	5										
	3.8	6+30									40	45	26	28	12	12	10	10	6	6										
	7.6	15+60									65	85	40	70	28	37	22	27	15	17										
AP47	7.6	15+60																			15	17								
AP45	7.6	15+60									65	85	40	70	28	37	22	27	15	17										
AP46 / AP48	7.6	15+60																			15	17	7	8	5	6	3	4		
AP60	15.5	15+60															44	54	30	34	30	34	14	16	10	12				
AP62	15.5	15+60																								6	8			

NOTE:

- ◆ Actuator AP48 is available for valves size DN250 with reduced bore only
- ◆ Valve size DN250 full bore use AP63 actuator only.
- ◆ Valve size DN250 full bore is available with balanced construction only

cl. IV : metal seat tightness class IV - ANSI FCI 70.2 - IEC 60534-4
cl. VI : soft seal class VI - ANSI FCI 70.2 - IEC 60534-4
the pressure drop values must be used with in the body rating limit

DIMENSIONS

DN	A mm	B mm	C mm - Standard trim			C mm - Balanced trim			G mm
			Std. bonnet	Bonnet with bellows	Finned / Extended bonnet	Std. bonnet	Bonnet with bellows	Finned / Extended bonnet	
DN15	130	47.5	126	226	163	—	—	—	100
DN20	150	52.5	126	226	163	—	—	—	100
DN25	160	57.5	129	228	173	—	—	—	100
DN32	180	70	129	228	173	—	—	—	100
DN40	200	75	128	226	185	—	—	—	100
DN50	230	82.5	128	226	185	157	256	214	100
DN65 (*)	290	92.5	165	292	255	218	334	277	100
DN80	310	100	187	306	260	230	348	282	100
DN100	350	117.5	184	307	310	245	365	310	100
DN125	400	135	256	369	369	352	472	394	120
DN150	480	150	259	372	372	356	476	398	120
DN200	600	187.5	283	395	395	380	500	422	120
DN250	730	225	—	—	—	453	650	650	230

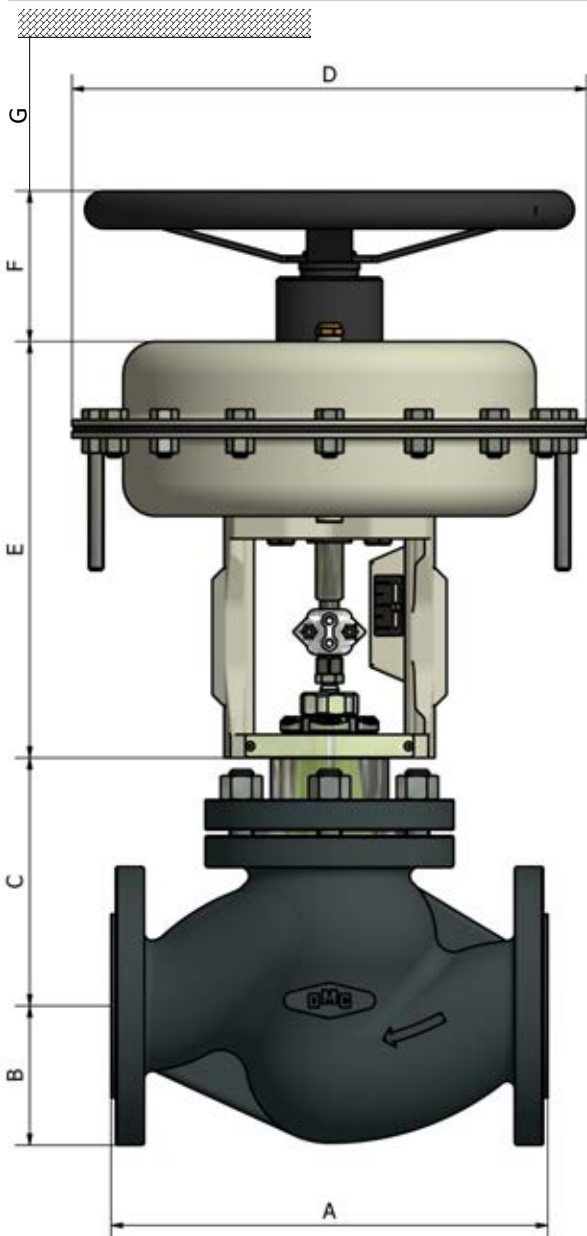

(*) According to standard EN1092-2 DN65 valves in cast iron flanged PN16 must be provided with 4 holes. They can be supplied with 8 holes only at the specific request of the customer.

ACTUATOR from DN15 to DN200

TYPE	Ø D mm	E mm	F mm		THRUST AREA (cm ²)	THRUST VOLUME liter
			N.A. (DIR.)	N.C. (INV.)		
AP23	230	245	135	85	203	~ 1.8
AP28	275	253			304	~ 3
AP34 AP35	342	276	185	85	475	~ 5.7
AP43 AP44	430	303	300	150	744	~ 11.5
AP45		393				
AP47		335	300	150		
AP46		425	300	150		
AP60	600	450	300	150	1690	~ 32
AP62	600	480	300	150	1690	~ 40

ACTUATOR for DN250 only

TYPE	Ø D mm	E mm	F mm		THRUST AREA (cm ²)	THRUST VOLUME liter
			N.A. (DIR.)	N.C. (INV.)		
AP48	430	570	300	150	744	~ 13.5
AP63	600	625	330	180	1690	~ 46

PNEUMATIC PISTON SERIES OP

The OP series pneumatic actuators are used especially for multi-spring piston valves with ON-OFF function. Available in 2 sizes, are extremely compact. Equipped with mechanical stroke indicator, the integral yoke meets Std CEI EN60534-6-1 to direct mounting accessories such as, switches, etc ...

TECHNICAL DATA

TYPE	Piston type - multispring
CONTROL SIGNAL	from 90 psi (6 bar) to 145 psi (10 bar)
MAX AIR SUPPLY PRESSURE	145 psi (10 bar)
PNEUMATIC CONNECTION	1/4" NPF-F
AMBIENT TEMPERATURE	-4÷160°F (-20+70°C)

MATERIALS

	STANDARD	ON REQUEST
CASING	Painted Aluminium	Electropolished Stainless Steel
YOKE	Painted Carbon steel	Electropolished Stainless Steel
BOLTS AND NUTS	A193 B7 - A194 2H	Other materials
PISTON	NBR	//
SPLINDE	ASTM 182 F304	//
VALVE CLAMP CONNECTION	ASTM A 351 CF8	//
SPRING	EN 10270-1SH painted	Stainless steel
INTERNAL PARTS	Zinc plated carbon steel	Stainless steel

PROTECTIVE COATING

STANDARD	Finish powder coat polyester RAL 7032
ON REQUEST	Painting for see environment Customer specification



ACCESSORIES

- ◆ Alarm contacts
- ◆ Air filter regulator
- ◆ Solenoid valves
- ◆ Lock-Up pneumatic device

MAXIMUM ADMISSIBLE PRESSURE DROPS IN bar (FLUID OPEN) FOR UNBALANCED

ACTUATOR	CV 6	CV 8	CV 13	CV 19	CV 29	CV 50	CV 75	CV 112	CV 173 CV190
OP10	12	12	12	12	12	12			
OP16							12	8	3

DIMENSIONS

DN	A mm	B mm		C mm - Standard trim			C mm - Balanced trim			G mm
		PN16	PN25	Std. bonnet	Bonnet with bellows	Finned / Extended bonnet	Std. bonnet	Bonnet with bellows	Finned / Extended bonnet	
DN15	130	47.5	47.5	126	226	163	—	—	—	100
DN20	150	52.5	52.5	126	226	163	—	—	—	100
DN25	160	57.5	57.5	129	228	173	—	—	—	100
DN32	180	70	70	129	228	173	—	—	—	100
DN40	200	75	75	128	226	185	—	—	—	100
DN50	230	82.5	82.5	128	226	185	157	256	214	100
DN65 (*)	290	92.5	92.5	165	292	255	218	334	277	100
DN80	310	100	100	187	306	260	230	348	282	100
DN100	350	110	117.5	184	307	310	245	365	310	100

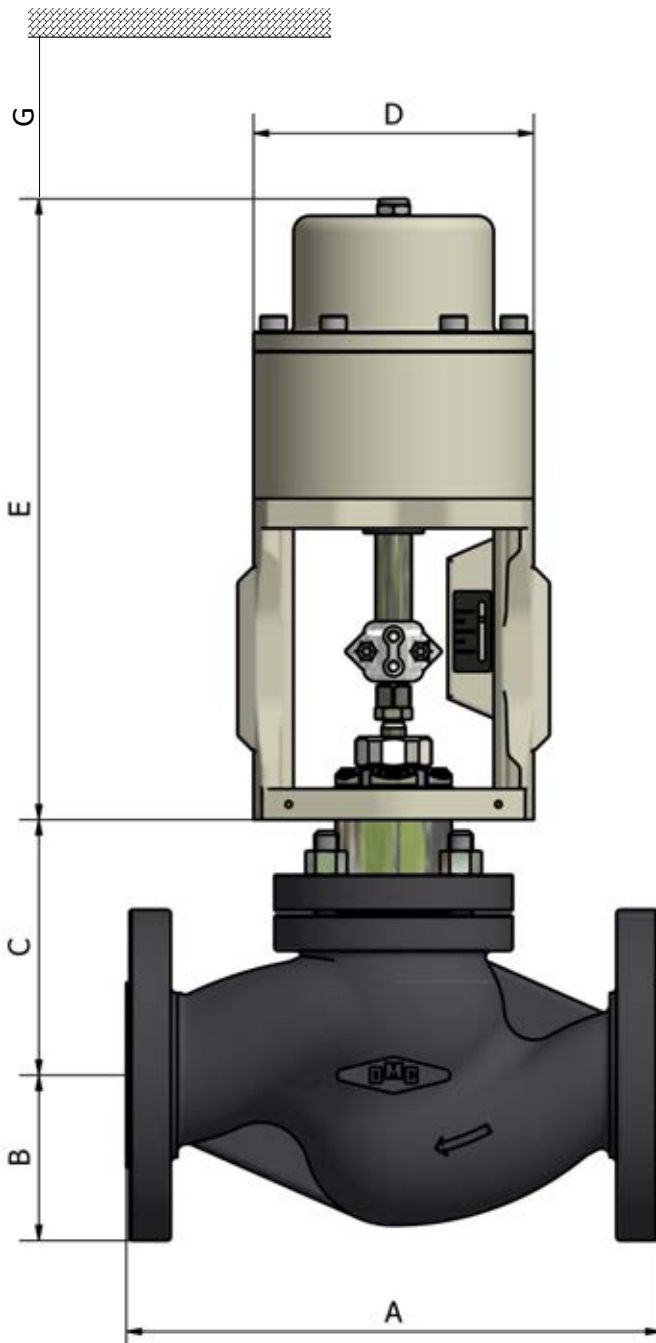

(*) According to standard EN1092-2 DN65 valves in cast iron flanged PN16 must be provided with 4 holes. They can be supplied with 8 holes only at the specific request of the customer.

ACTUATOR				
TYPE	Ø D inches (mm)	E inches (mm)		
		½ - 1" ½	2"	3" - 4"
OP10	9.05 (230)	10.51 (267)	11.50 (292)	//
OP16	10.82 (275)	//	//	13.19 (335)

ELECTRIC ACTUATORS

The OMC control valves can be supplied with electric actuators of the best manufacturers to meet the most varied demands in the industrial processes.



AVAILABLE ENDS CONNECTIONS



RAISED FACE



RING JOINT FACE



MALE FACE



FEMALE FACE



FLAT FACE



GROOVE FACE

VALVE BODY WEIGHT (Kg)

SIZE	Standard	Finned / Extended	With bellows
DN15	4.7	5.2	5.9
DN20	5.4	5.9	6.6
DN25	6.8	7.5	7.9
DN32	8.2	8.8	9.3
DN40	11.2	12.3	12.9
DN50	14.3	15.4	15.9
DN65	25.3	28.4	29.5
DN80	28.9	31.9	33
DN100	39.2	48.8	43.1
DN125	83.9	91.8	90.9
DN150	109.1	117	115.8
DN200	165	172.8	171.5
DN250	275	280	280

PNEUMATIC ACTUATOR WEIGHT

TYPE	SIGNAL	ACTUATOR	HAND WHEEL
AP23	3÷15 / 6÷18 / 6÷30	7	1
	15÷60	8	
AP28	3÷15 / 6÷18 / 6÷30	9	
	15÷60	10	
AP34 / AP35	3÷15 / 6÷18 / 6÷30	15	2
	15÷60	17	
AP43 / AP44	3÷15 / 6÷18 / 6÷30	27	3
	15÷60	32	7
AP45	15÷60	38	7
AP46	15÷60	45	7
AP47	15÷60	45	7
AP48	15÷60	57	7
AP60	15÷60	155	7
AP62	15÷60	169	7
AP63	15÷60	181	8
OP10	ON-OFF	8	//
OP16	ON-OFF	13	//

The contents of this publication are presented for information purpose only. We reserve to modify or improve the designs or specifications of such products at any time without notice



Products for Plant Automation
www.schibuola.com - info@schibuola.com
 tel. 011-6991507 - 011-6502223 cell. 3355367761

