

Catalogo Prodotti Inox

Garantire efficienza: una scelta di qualità

Leadercom Srl

Forniture industriali è una realtà nata per essere competitiva, e strutturata appositamente per crescere: secondo le richieste del mercato, in linea con le innovazioni tecnologiche.

Per investire in termini di qualità ed efficienza abbiamo implementato un sistema di magazzino verticale: grazie all'utilizzo intensivo delle superfici, è infatti possibile stoccare una quantità superiore di merci rispetto ai magazzini tradizionali.

Il nostro punto fermo è e sarà sempre la soddisfazione della clientela: ci impegniamo e aggiorniamo costantemente per garantire un servizio puntuale ed efficiente.

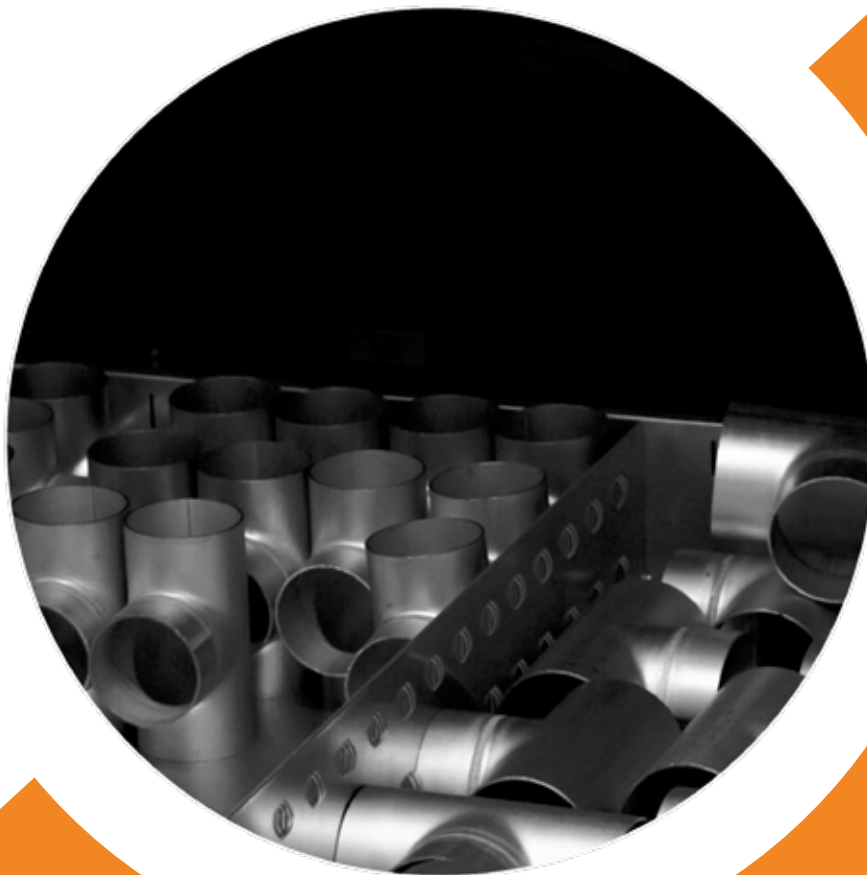

DIN 11864
DIN 11853

DIN 11851

SMS

CLAMP

ISO
Saldare

GAS
massello

GAS
microfuso

Valvole e
Accessori

FLANGE

Sistemi di
Lavaggio

FLANGE

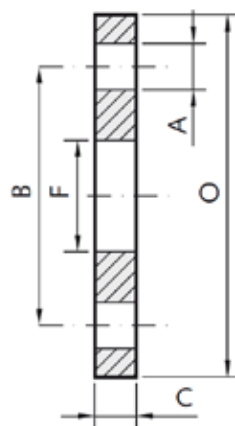

AISI 304/316

DN	O mm	B mm	F mm	C mm	A mm	nr fori
10	90	60	18	12	14	4
15	95	65	22	12	14	4
20	105	75	27,5	14	14	4
25	115	85	34,5	14	14	4
32	140	100	43,5	16	18	4
40	150	110	49,5	16	18	4
50	165	125	61,5	18	18	4
65	185	145	77,5	18	18	4
80	200	160	90,5	20	18	4
100	220	180	116	22	18	8
125	250	210	141,5	22	18	8
150	285	240	270,5	24	22	8
200	340	295	221,5	24	22	8
250	395	350	276,5	26	22	12
300	445	400	327,5	26	22	12
350	505	460	359,5	30	22	16
400	565	515	411	32	26	16
450	615	565	462	32	26	20
500	670	620	513,5	34	26	20
600	780	725	616,5	36	30	20
700	895	840	714,2	38	30	24
800	1015	950	815,8	40	33	24
900	1115	1050	917,4	42	33	28
1000	1230	1160	1019	44	36	28

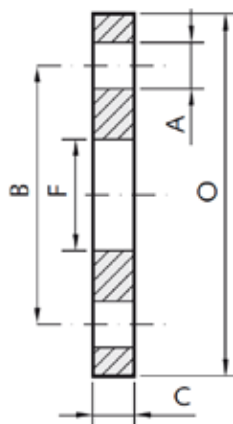

AISI 304/316

DN	O mm	B mm	F mm	C mm	A mm	nr fori
10	90	60	18	12	14	4
15	95	65	22	12	14	4
20	105	75	27,5	14	14	4
25	115	85	34,5	14	14	4
32	140	100	43,5	16	18	4
40	150	110	49,5	16	18	4
50	165	125	61,5	18	18	4
65	185	145	77,4	18	18	4
80	200	160	90,5	20	18	8
100	220	180	116	22	18	8
125	250	210	141,5	22	18	8
150	285	240	170,5	24	22	8
200	340	295	221,5	26	22	12
250	405	355	276,5	29	26	12
300	460	410	327,5	32	26	12
350	520	470	359	35	26	16
400	580	525	411	38	30	16
450	640	585	462	40	30	20
500	715	650	513,5	42	33	20
600	840	770	616,5	44	36	20
700	910	840	714,2	46	33	24

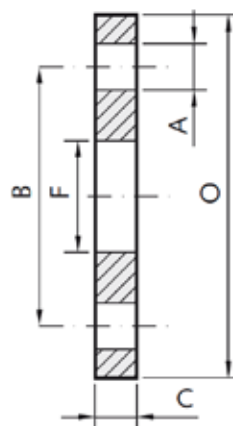

AISI 304/316

DN	O mm	B mm	F mm	C mm	A mm	nr fori
10	90	60	18	14	14	4
15	95	65	22	14	14	4
20	105	75	27,5	16	14	4
25	115	85	34,5	16	14	4
32	140	100	43,5	18	18	4
40	150	110	49,5	18	18	4
50	165	125	61,5	20	18	4
65	185	145	77,5	22	18	8
80	200	160	90,5	24	18	8
100	235	190	116	26	22	8
125	270	220	141,5	28	26	8
150	300	250	170,5	30	26	8
200	375	320	221,5	36	30	12
250	450	385	276,5	42	33	12
300	515	450	327,5	52	33	16
350	580	510	359,5	58	36	16
400	660	585	411	65	39	16
450	685	610	462	SP	39	20
500	755	670	513,5	SP	42	20
600	890	795	616,5	SP	48	20

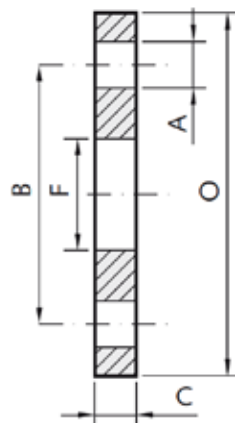

AISI 304/316

DN	O mm	B mm	F mm	C mm	A mm	nr fori
10	90	60	18	14	14	4
15	95	65	22	14	14	4
20	105	75	27,5	16	14	4
25	115	85	34,5	16	14	4
32	140	100	43,5	18	18	4
40	150	110	49,5	18	18	4
50	165	125	61,5	20	18	4
65	185	145	77,5	20	18	4 o 8
80	200	160	90,5	20	18	8
100	220	180	116	22	18	8
125	250	210	141,5	22	18	8
150	285	240	170,5	24	22	8
200	340	295	221,5	24	22	8
250	395	350	276,5	26	22	12
300	445	400	327,5	26	22	12
350	505	460	359,5	30	22	12
400	565	515	411	32	26	16
450	615	565	462	36	26	20
500	670	620	513,5	38	26	20
600	780	725	616,5	42	30	20

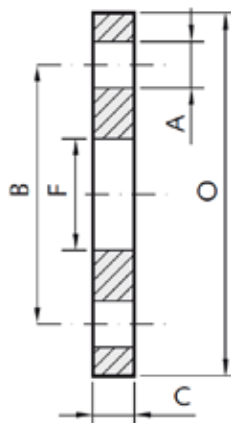

AISI 304/316

DN	O mm	B mm	F mm	C mm	A mm	nr fori
10	90	60	18	14	14	4
15	95	65	22	14	14	4
20	105	75	27,5	16	14	4
25	115	85	34,5	16	14	4
32	140	100	43,5	18	18	4
40	150	110	49,5	18	18	4
50	165	125	61,5	20	18	4
65	185	145	77,5	20	18	4 o 8
80	200	160	90,5	20	18	8
100	220	180	116	22	18	8
125	250	210	141,5	22	18	8
150	285	240	170,5	24	22	8
200	340	295	221,5	24	22	12
250	405	355	276,5	29	26	12
300	460	410	327,5	32	26	12
350	520	470	359,5	35	26	16
400	580	525	411	38	30	16
450	640	585	462	42	30	20
500	715	650	513,5	46	33	20
600	840	770	616,5	55	36	20

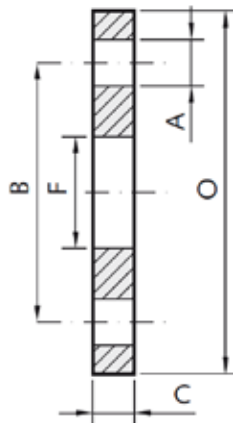

AISI 304/316

DN	O mm	F mm	C mm	B mm	A mm	nr fori
15	80	22,0	12	55	11	4
20	90	27,5	14	65	11	4
25	100	34,5	14	75	11	4
32	120	43,5	16	90	14	4
40	130	49,5	16	100	14	4
50	140	61,5	16	110	14	4
65	160	77,5	16	130	14	4
80	190	90,5	18	150	18	4
100	210	116,0	18	170	18	4
125	240	141,5	20	200	18	8
150	265	170,5	20	225	18	8
200	320	221,5	22	280	18	8
250	375	276,5	24	335	18	12
300	440	327,5	24	395	22	12
350	490	359,5	26	445	22	12
400	540	411,0	28	495	22	16
450	595	462,0	30	550	22	16
500	645	513,5	30	600	22	20
600	755	616,5	32	705	26	20

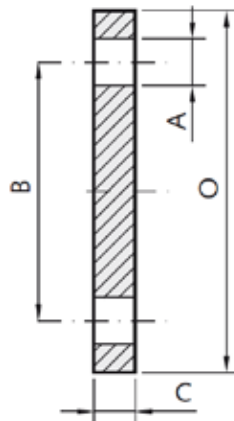

AISI 304/316

DN	O mm	C mm	B mm	A mm	nr fori
15	95	16	65	14	4
20	105	18	75	14	4
25	115	18	85	14	4
32	140	18	100	18	4
40	150	18	110	18	4
50	165	20	125	18	4
65	185	22	145	18	8
80	200	24	160	18	8
100	235	24	190	22	8
125	270	26	220	26	8
150	300	28	250	26	8
200	375	36	320	30	12
250	450	38	385	33	12
300	515	42	450	33	16
350	580	46	510	36	16
400	660	50	585	39	16
450	685	57	610	39	20
500	755	57	670	42	20

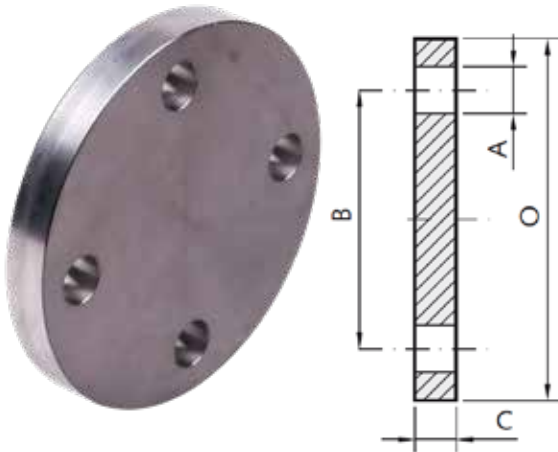
RX104**Flangia cieca FORGIATA EN1092-1 tipo 05/A PN10**

DN	O mm	C mm	B mm	A mm	nr fori
200	340	24	295	22	12
250	395	26	350	22	12
300	445	26	400	22	12
350	505	26	460	22	16
400	565	26	515	26	16
450	615	28	565	26	20
500	670	28	620	26	20

AISI 304/316**Flangia cieca FORGIATA EN1092-1 tipo 05/A PN16****RX108**

DN	O mm	C mm	B mm	A mm	nr fori
50	165	18	125	18	4
65	185	18	145	18	4 o 8
80	200	20	160	18	8
100	220	20	180	18	8
125	250	22	210	18	8
150	285	22	240	22	8
200	340	24	295	22	8
250	405	26	355	26	12
300	460	28	410	26	12
350	520	30	470	26	16
400	580	32	525	30	16
450	640	40	585	30	20
500	715	44	650	33	20

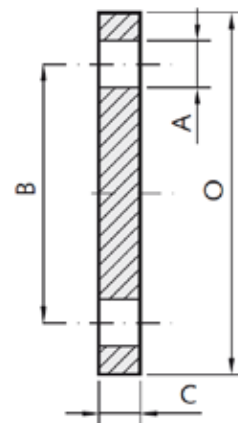
**AISI 304/316**

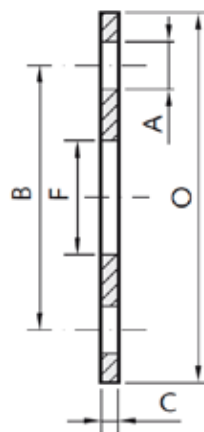
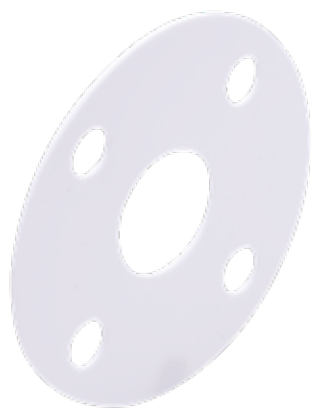

Dn	O mm	B mm	F mm	C mm	A mm	nr fori
10	90	60	18	2	14	4
15	95	65	22	2	14	4
20	105	75	27,5	2	14	4
25	115	85	34,5	2	14	4
32	140	100	43,5	2	18	4
40	150	110	49,5	2	18	4
50	165	125	61,5	2	18	4
65	185	145	77,5	2	18	4 - 8
80	200	160	90,5	2	18	8 - 12
100	220	180	116	2	18	8
125	250	210	141,5	2	18	8
150	285	240	170,5	2	22	8
200	340	295	221,5	2	22	8 - 12
250	405	355	276,5	2	26	12
300	460	410	327,5	2	26	12
350	520	470	359,5	2	26	12 - 16
400	580	525	411	2	30	16
450	640	585	462	2	30	20
500	715	650	513,5	2	33	20
600	840	770	616,5	2	36	20

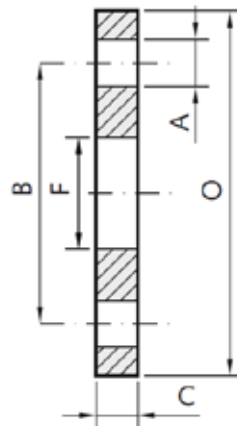

DN	DE	F mm	O mm	C mm	B mm	A mm	nr fori
10	17,2	19	90	12	60	14	4
15	21,3	24	95	12	65	14	4
20	26,9	30	105	12	75	14	4
25	33,7	36	115	12	85	14	4
32	42,2	46	140	16	100	18	4
40	48,3	54	150	16	110	18	4
50	60,3	65	165	16	125	18	4
65	76,1	81	185	16	145	18	4
80	88,9	95	200	18	160	18	8
100	114,3	119	220	18	180	18	8
125	139,7	144	250	18	210	18	8
150	168,3	173	285	18	240	22	8
200	219,1	225	340	20	295	22	8
250	273	279	395	22	350	22	12
300	323,9	329	445	22	400	22	12
350	355,6	362	505	22	460	22	16
400	406,4	413	565	25	515	25	16
450	457	466	615	24	565	25	20
500	508	517	670	18	620	25	20
600	610	620	780	30	725	30	20
700	711	721	895	32	840	30	24
800	813	824	1015	36	950	33	24

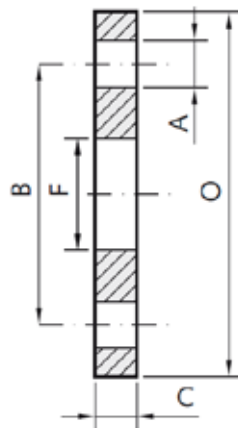

DN	DE	F mm	O mm	C mm	B mm	A mm	nr fori
10	13-14	19	90	12	60	14	4
15	18-20	24	95	12	65	14	4
20	23-25	30	105	12	75	14	4
25	28-30	34	115	12	85	14	4
32	35-38	40	140	16	100	18	4
40	43-44,5	48	150	16	110	18	4
50	53,56	58	165	16	125	18	4
65	69	73	185	16	145	18	4
80	84-86	90	200	18	160	18	6
100	104-106	110	220	18	180	18	8
125	129-131	135	250	18	210	18	8
150	154-156	160	285	18	240	22	8
200	204-206	212	340	20	295	22	8
250	254-256	262	395	22	350	22	12
300	304-306	312	445	22	400	22	12
350	356	362	505	22	460	22	16
400	406	413	565	25	515	25	16
450	456	466	515	25	565	25	20
500	506	517	670	28	620	25	20
600	606	620	780	30	725	30	20
700	706	721	895	32	840	30	24
800	806	824	1015	36	950	33	24

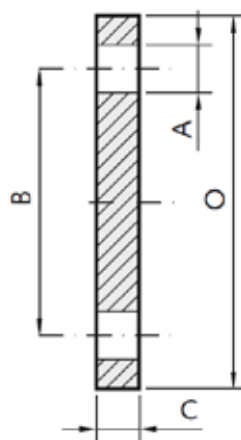

DN	O mm	C mm	B mm	A mm	nr fori
10	90	12	60	14	4
15	95	12	65	14	4
20	105	12	75	14	4
25	115	12	85	14	4
32	140	16	100	18	4
40	150	16	110	18	4
50	165	16	125	18	4
65	185	16	145	18	4
80	200	18	160	18	8
100	220	18	180	18	8
125	250	18	210	18	8
150	285	18	240	22	8
200	340	20	295	22	8
250	395	22	350	22	12
300	445	22	400	22	12
350	505	22	460	22	16
400	565	25	515	25	16
450	615	25	565	25	20
500	670	28	620	25	20

Leadercom Srl

Via Edison Volta, 25/A
43125 Parma PR

Tel: 0521 989313
E-mail: info@leadercom.it
www.leadercom.it

Progetto grafico:

Webscriptum />

Via Nicolò Copernico 18/b
42124 Reggio Emilia RE
www.webscriptum.com

Tutti i diritti sono riservati. All rights reserved.

Nessuna parte di questo catalogo può essere riprodotta o trasmessa in qualsiasi forma o mezzo, senza l'autorizzazione scritta dei titolari del copyright.