

Catalogo Prodotti Inox

Garantire efficienza: una scelta di qualità

Leadercom Srl

Forniture industriali è una realtà nata per essere competitiva, e strutturata appositamente per crescere: secondo le richieste del mercato, in linea con le innovazioni tecnologiche.

Per investire in termini di qualità ed efficienza abbiamo implementato un sistema di magazzino verticale: grazie all'utilizzo intensivo delle superfici, è infatti possibile stoccare una quantità superiore di merci rispetto ai magazzini tradizionali.

Il nostro punto fermo è e sarà sempre la soddisfazione della clientela: ci impegniamo e aggiorniamo costantemente per garantire un servizio puntuale ed efficiente.

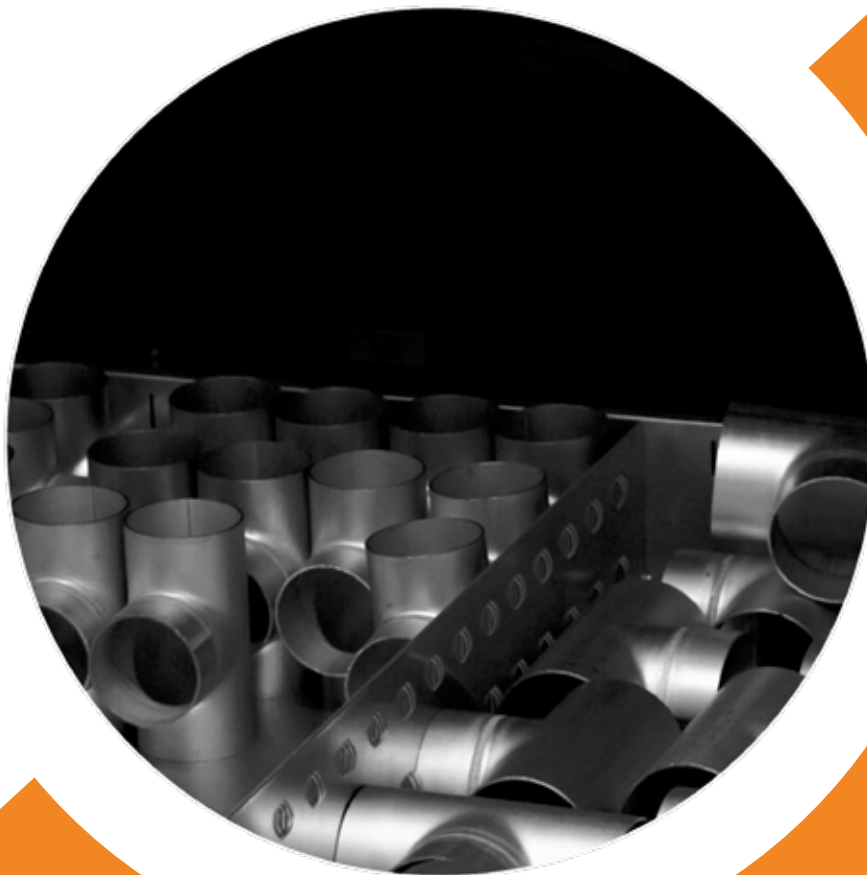

DIN 11864
DIN 11853

DIN 11851

sms

CLAMP

ISO
Saldare

GAS
massello

GAS
microfuso

Valvole e
Accessori

FLANGE

Sistemi di
Lavaggio

sms

RX4079**Girella SMS**

sms

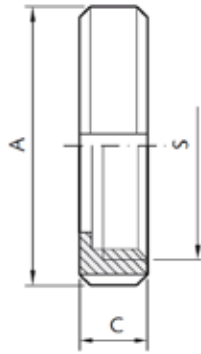

DN	S mm	A mm	C mm
25	40	51	19
38	60	74	23
51	70	84	24
63	85	100	28
76	98	114	30
101	132	150	31
104	125	138	31

AISI 304**Raccordo SMS maschio a saldare****RX4059**

DN	F mm	A mm	C mm
25	25,4	35,5	15,5
38	38,1	55	16
51	50,8	65	17
63	63,5	80	17
76	76,1	93	19
101	101,6	127	19

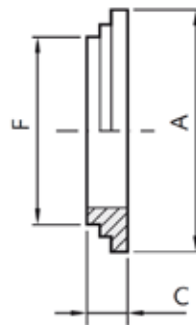
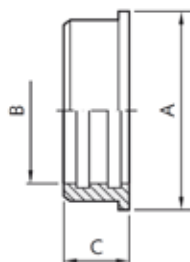
**AISI 316****RX4069****Raccordo SMS maschio a mandrinare**

DN	A mm	B mm	C mm
25	35,5	25,6	17
38	55	38,3	20
51	65	51	20
63	80	63,7	25
76	93	76,4	30
101	127	101,9	27
104	118	104,3	27

AISI 316

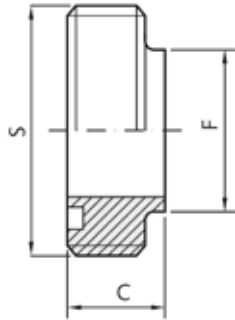
RX4039**Raccordo SMS femmina a saldare**

DN	S mm	F mm	C mm
25	40	25,4	19
38	60	38,1	23
51	70	50,8	23
63	85	63,5	27
76	98	76,1	27
101	132	101,6	30

AISI 316

SMS

Raccordo SMS femmina a mandrinare**RX4049**

DN	S mm	B mm	C mm
25	40	25,6	20
38	60	38,3	23
51	70	51	25
63	85	63,8	30
76	98	76,4	35
101	132	101,9	30
104	125	104,3	30

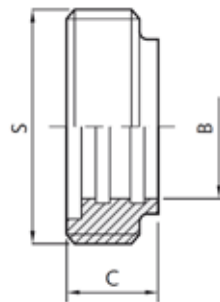
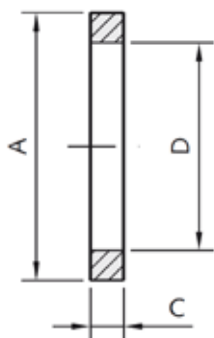
AISI 316**RX4091****Guarnizione per raccordo SMS-EPDM-FKM**

DN	A mm	C mm	D mm
25	32	5,5	25
38	48	5,5	38
51	61	5,5	51
63	73,5	5,5	63,5
76	86	5,5	76,1
101	113	5,5	101,6
104	114	5,5	104

RX4121**Tappo di chiusura SMS**

sms

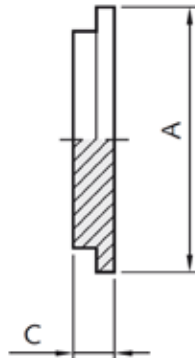

Dn	A mm	C mm
25	35,5	7,5
38	55	9
51	65	9
63	80	9
76	93	10
101	127	12

AISI 316**Curva 180° a mandrinare lucido esterno-interno (Ra <0,8µm)****RX511**

Dn	F mm	S mm	B mm	C mm
25	25,4	1,50	81	75
38	38,1	1,50	106	90
51	50,8	1,50	146	100
63	63,5	1,50	172	115
76	76,1	2	174	130
101	101,6	2	220	150

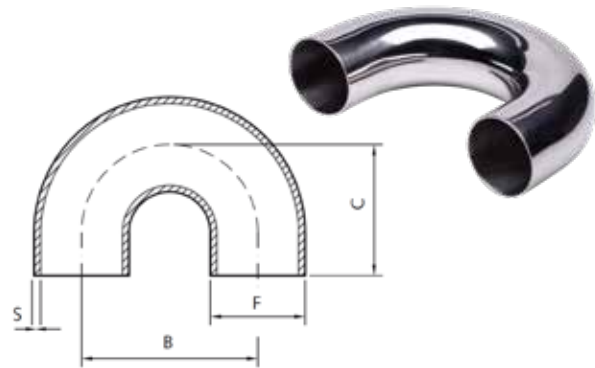
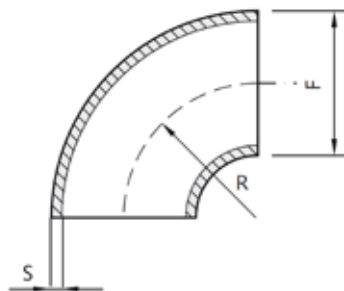
**AISI 316****RX5240****Curva 90° a saldare lucida (Ra <0,8µm)**

Dn inch	F mm	S mm	R mm
1/2	12,0	1,65	19,1
3/4	19,05	1,65	28,6
1	25,4	1,65	38,1
1 1/2	38,1	1,65	57,2
2	50,8	1,65	76,2
2 1/2	63,5	1,65	114,3
3	76,1	1,65	114,3
4	101,6	2,10	152,4

AISI 316

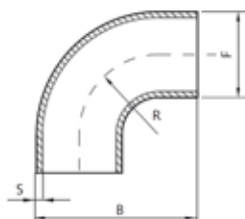
RX5241**Curva 90° a mandrinare lucida (Ra <0,8µm)****AISI 316**

DN	F mm	S mm	B mm
1/2	12,7	1,65	45
3/4	19,05	1,65	60
25	25,4	1,65	65
38	38,1	1,65	85
51	50,8	1,65	110
63	63,5	1,65	115
76	76,1	1,65	130
101	101,6	2,10	150

SMS

Curva 45° a saldare lucida (Ra <0,8µm)**RX5245****2WK-45°**

DN	F mm	S mm	B mm
1/2	12,7	1,65	19,1
3/4	19,05	1,65	28,6
25	25,4	1,65	80
38	38,1	1,65	105
51	50,8	1,65	103
63	63,5	1,65	115
76	76,1	1,65	135
101	101,6	2,10	150

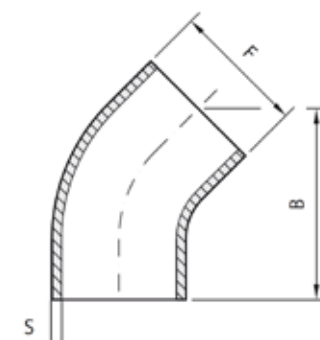
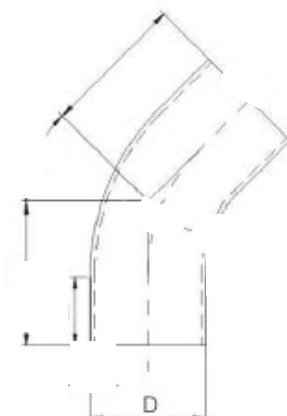
AISI 316**RX5242****Curva 45° mandrinare lucida**

DN	L mm	D mm
1/2"	37,9	12,7
3/4"	41,8	19,1
1"	45,8	25,4
1 1/4"	49,8	31,8
1 1/2"	53,7	38,1
2"	61,8	50,8
2 1/2"	69,6	63,5
3"	77,5	76,2
4"	93,2	101,6
5"	118,9	127
6"	134,7	152,4

RX5490

TEE a mandrinare lucido (Ra <0,8µm)

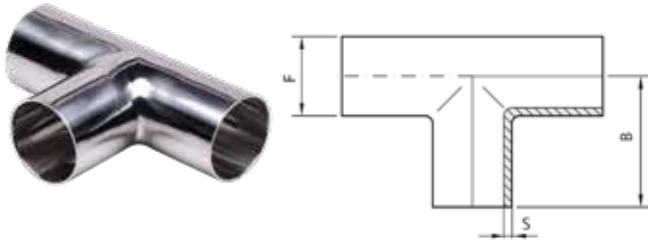

DN inch	F mm	S mm	A mm	B mm
1/2	12,7	1,65	19,05	38,1
3/4	19,05	1,65	47,6	95,2
1	25,4	1,65	47,6	95,2
1/2	38,1	1,65	57,2	114,4
2	50,8	1,65	76,2	152,4
2 1/2	63,5	1,65	76,2	152,4
3	76,2	1,65	82,6	165,2
4	101,6	2,10	98,5	197,0

AISI 316

sms

TEE ridotto a mandrinare lucido (Ra <0,8µm)

RX5495

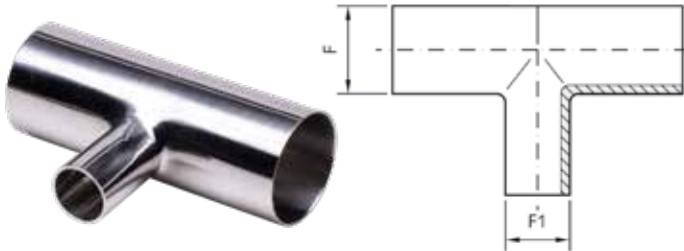

F	F1	F	F1
19,05	12,7	63,5	38,1
25,4	12,7	63,5	50,8
25,4	19,05	76,1	25,4
38,1	12,7	76,1	38,1
38,1	19,05	76,1	50,8
38,1	25,4	76,1	63,5
50,8	19,05	101,6	25,4
50,8	25,4	101,6	38,1
50,8	38,1	101,6	50,8
63,5	19,05	101,6	63,5
63,5	25,4	101,6	76,1

AISI 316

RX606

Croce a mandrinare lucida (Ra <0,8µm)

DN	F mm	B mm	D mm
10	12,7	-	9,4
15	19,1	-	15,8
25	25,4	55	22,1
38	38,1	70	34,8
51	50,8	82	47,5
63	63,5	105	60,2
76	76,1	110	84,9
101	101,6	130	97,6

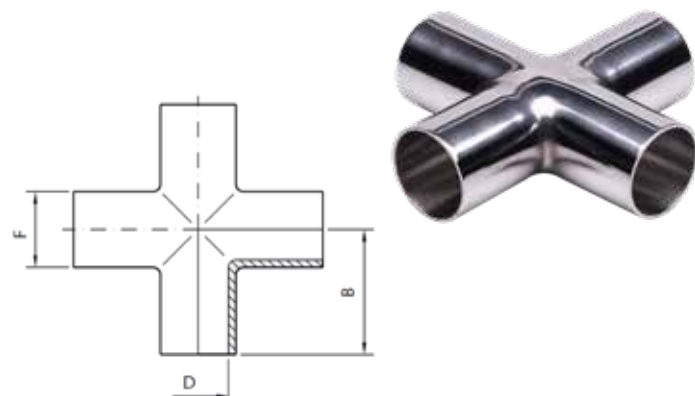

AISI 316

RX651

Riduzione concentrica a saldare lucida (Ra <0,8µm)

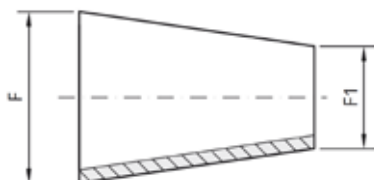

AISI 316

F	F1	F	F1
19,05	12,7	63,5	38,1
25,4	12,7	63,5	50,8
25,4	19,05	76,1	25,4
38,1	12,7	76,1	38,1
38,1	19,05	76,1	50,8
38,1	25,4	76,1	63,5
50,8	12,7	101,6	25,4
50,8	19,05	101,6	38,1
50,8	25,4	101,6	50,8
50,8	38,1	101,6	63,5
63,5	19,05	101,6	76,1
63,5	25,4		

SMS

Riduzione concentrica a mandrinare lucida (Ra <0,8µm)

RX660

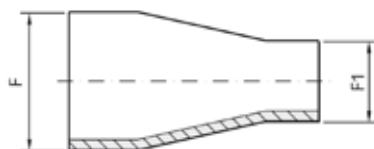

AISI 316

F	F1	F	F1
25,4	12,7	63,5	50,8
25,4	19,05	76,1	38,1
38,1	19,05	76,1	50,8
38,1	25,4	76,1	63,5
50,8	25,4	101,6	38,1
50,8	38,1	101,6	50,8
63,5	25,4	101,6	63,5
63,5	38,1	101,6	76,1

RX666

Riduzione eccentrica a saldare lucida (Ra <0,8µm)

F	F1	F	F1
19,05	12,7	63,5	38,1
25,4	12,7	63,5	50,8
25,4	19,05	76,1	25,4
38,1	12,7	76,1	38,1
38,1	19,05	76,1	50,8
38,1	25,4	76,1	63,5
50,8	12,7	101,6	25,4
50,8	19,05	101,6	38,1
50,8	25,4	101,6	50,8
50,8	38,1	101,6	63,5
63,5	19,05	101,6	76,1
63,5	25,4		

AISI 316

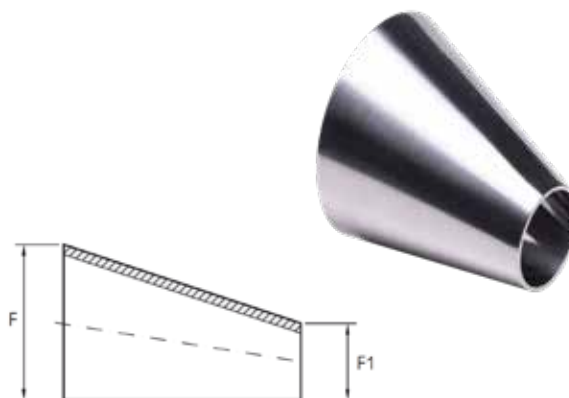

RX740

Reggitubo a cerniera " pesante " con attacco filettato GAS

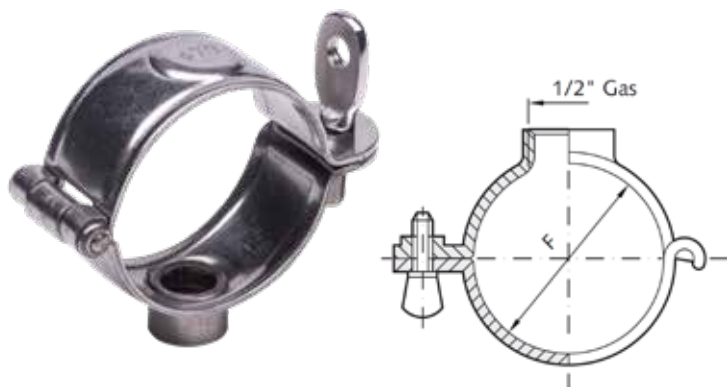

DN inch	F mm
1	25,4
1 1/2	38,1
2	50,8
2 1/2	63,5
3	76,1
4	101,6

A304

Leadercom Srl

Via Edison Volta, 25/A
43125 Parma PR

Tel: 0521 989313
E-mail: info@leadercom.it
www.leadercom.it

Progetto grafico:

Webscriptum />

Via Nicolò Copernico 18/b
42124 Reggio Emilia RE
www.webscriptum.com

Tutti i diritti sono riservati. All rights reserved.

Nessuna parte di questo catalogo può essere riprodotta o trasmessa in qualsiasi forma o mezzo, senza l'autorizzazione scritta dei titolari del copyright.